



Modelling of higher trophic levels with an large ecosystem model:

- state of the art
- limitations
- perspectives

Piet Ruardij



Modelling the North Sea:

Actual situation:

- 8+1 coupled hydrodynamical-ecosystems models available for the North Sea. (OSPAR workshop)
 - eco-hydrodynamical models
 - NP- models
 - NPZ(D) -models
 - full ecosystem models
 - only pelagic
 - with benthic return model
 - with benthos model
- Models are mostly used to model the effect of eutrophication on the primary production, nutrient distribution, on to forecast the chance on low oxygen concentrations.



Modelling the North Sea: Why a new model?

- **Experience with Box-(full) ecosystem models.**
- **Project of CEFAS:**
 - Development of ecological model capacity for studying eutrophication problems in the Southern North Sea
 - Field Projects on benthic-pelagic coupling.
- **BSIK-project in NIOZ:**
 - Studying effects of climate changes on functioning of the North Sea:
 - CO₂-dynamics
 - Effect on benthos
- **State of the art:**
 - (relative) cheap *cluster* computer
 - public domain software (GETM, GOTM, BFM/ERSEM)



North Sea model set-up: 144*120*25 (x*y*z): grid size:10 x 10 km

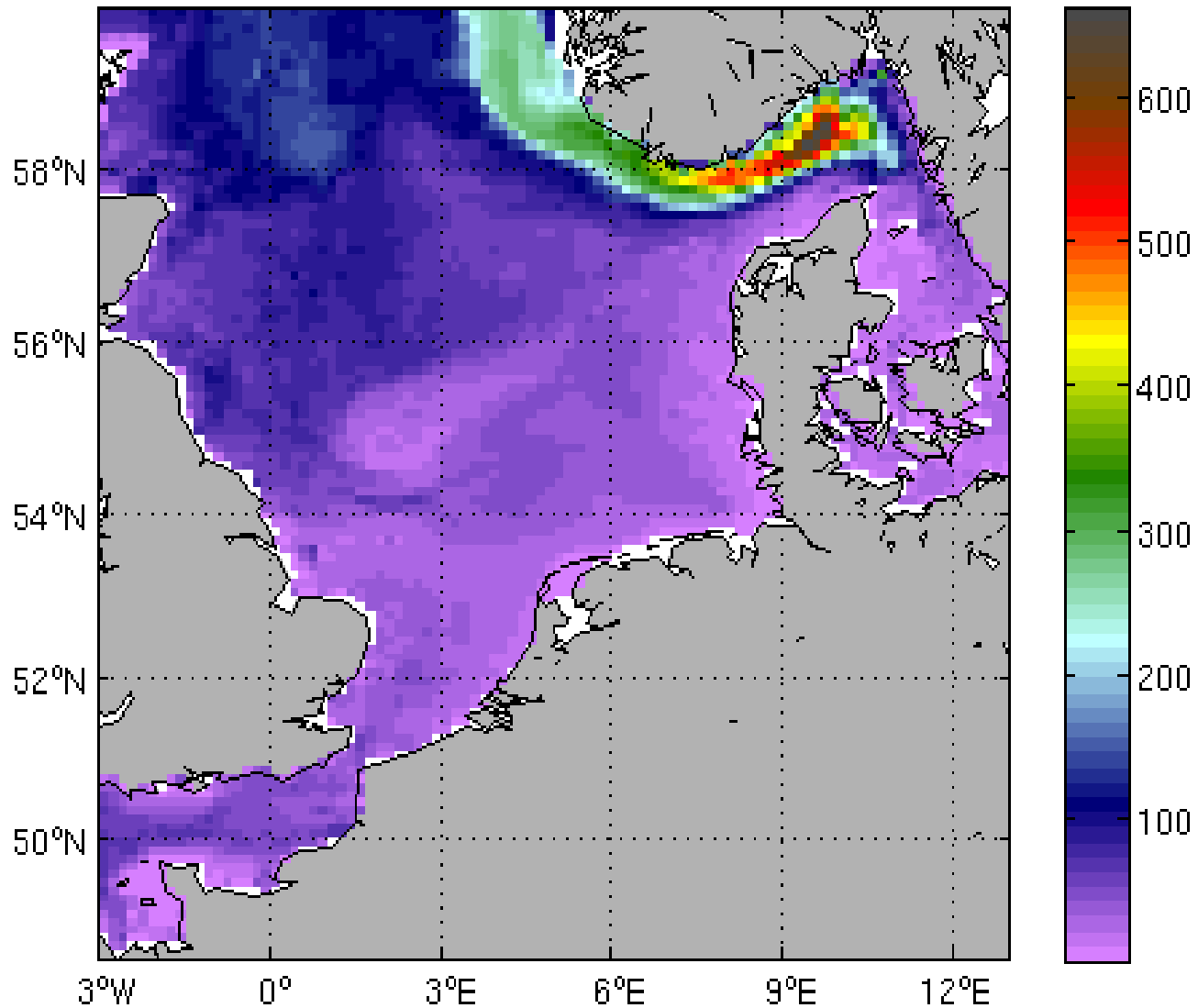



North Sea: grid size: 10 by 10 km

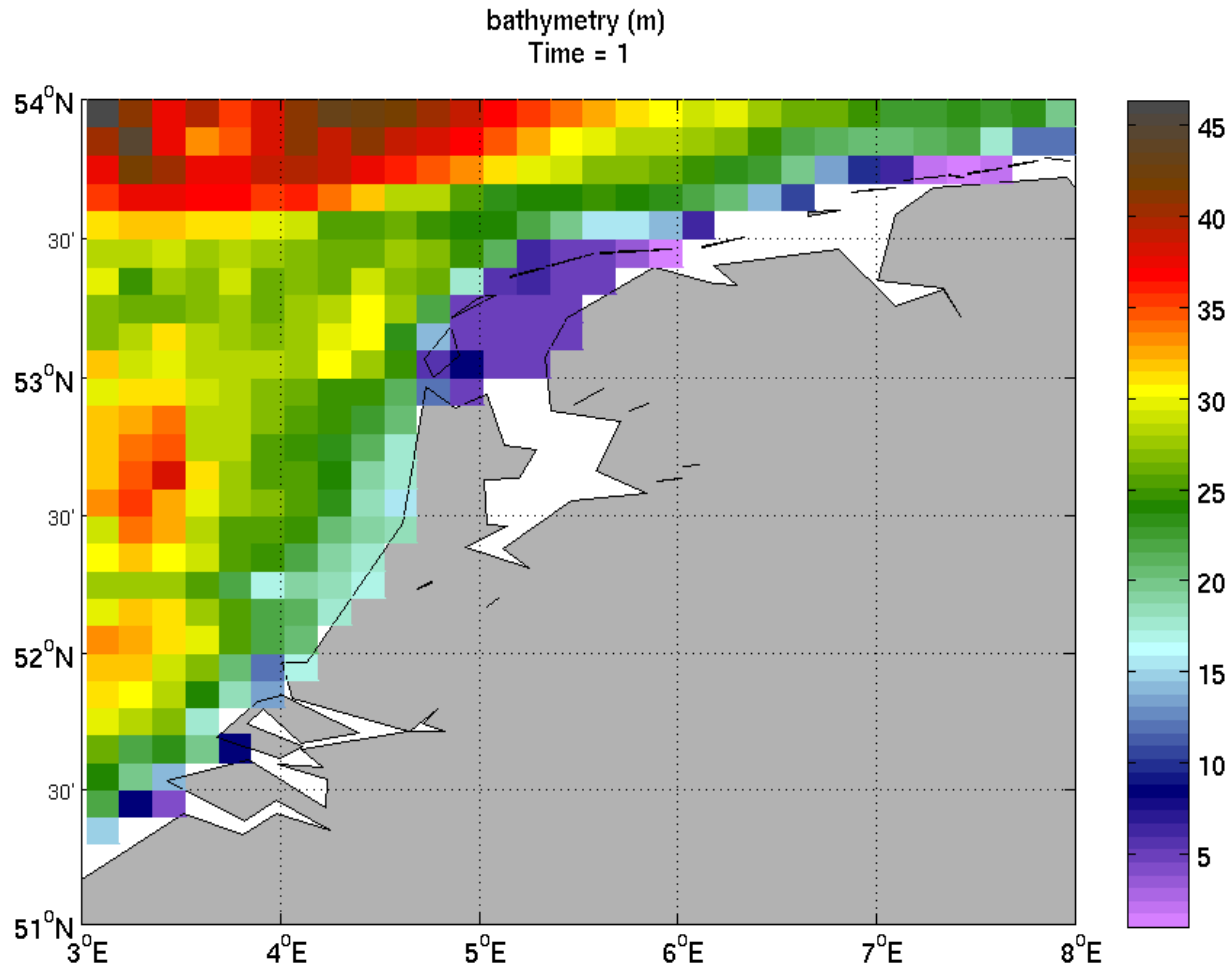



Coupled hydrodynamical ecosystem model: solving a set of coupled differential equations

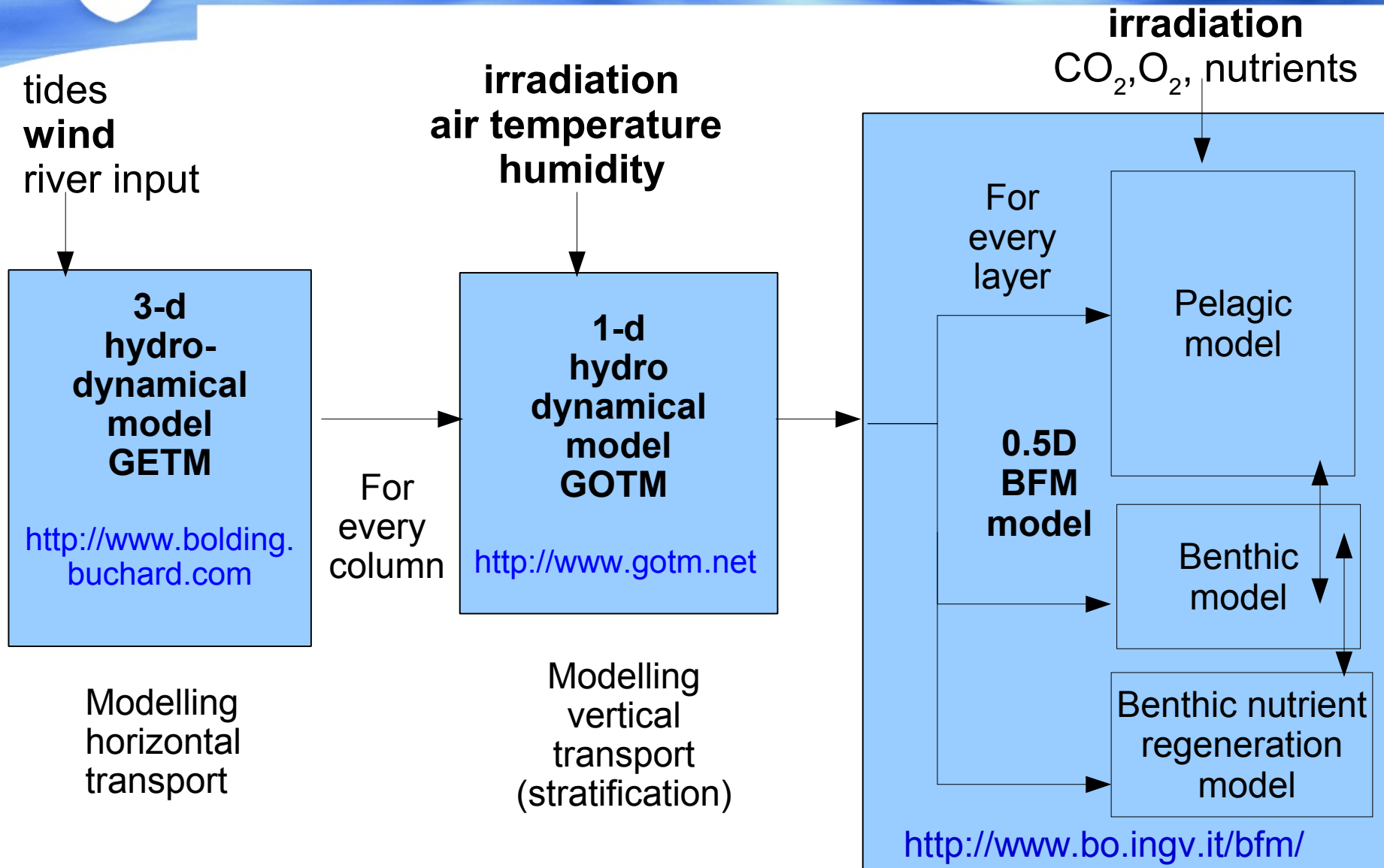



Model: Forcing & Boundary conditions

Meteo:

- Source :Reanalyzed data of ECWMF (precision: 1x1 degree)
- Variables: wind force,wind direction, cloudiness, humidity

Boundaries:

- OR:data from ocean model
- OR: climatological nutrient data +reflecting boundaries for other constituents

River Input:

- 80 rivers in GB
- 20 rivers continent

Silt:

- determines light climate for primary production
- OR: simple model calculating silt content on basis of wind fields and % silt in sediment
- OR: (in near future) : New silt model (Johan v.d.Molen,CEFAS)

Pelagic submodel of BFM (ERSEM)

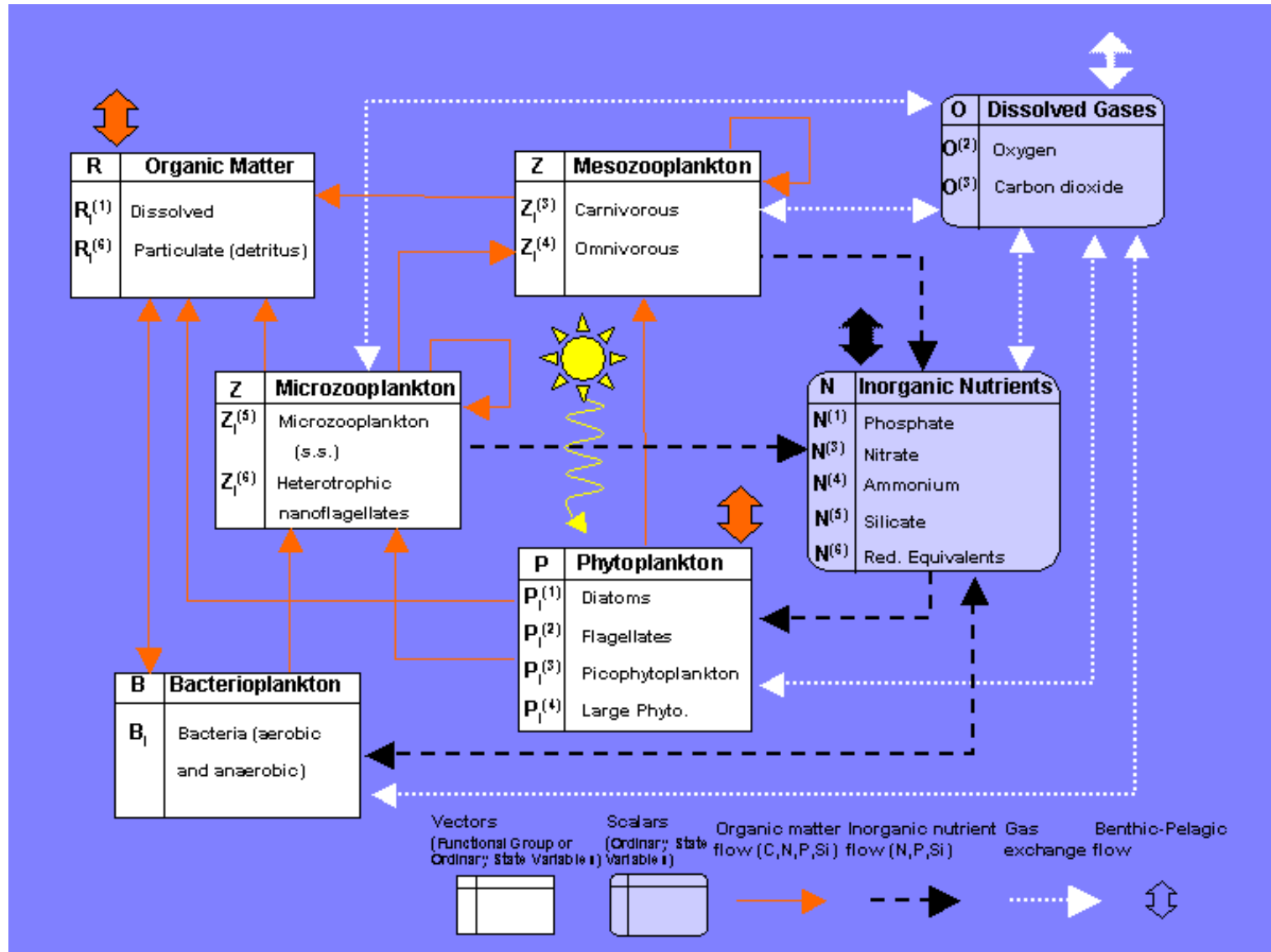

Structure Pelagic submodel

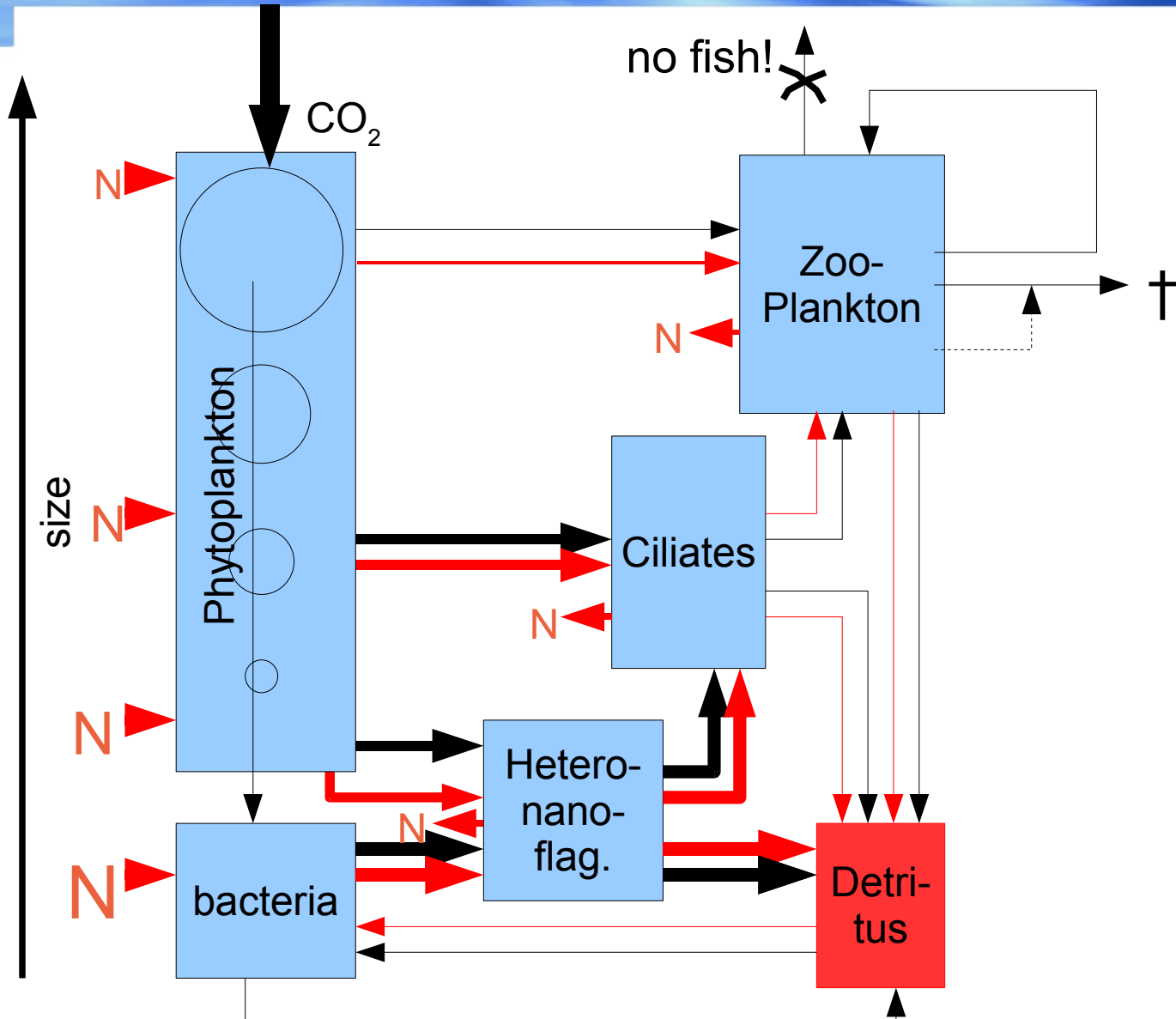



Pelagic structure : Phytoplankton model

- *C-fixation ONLY controlled by light*
- *In case of nutrient limitation fixated C is excreted!*
- *Hence: No fixed RedField ratios!*

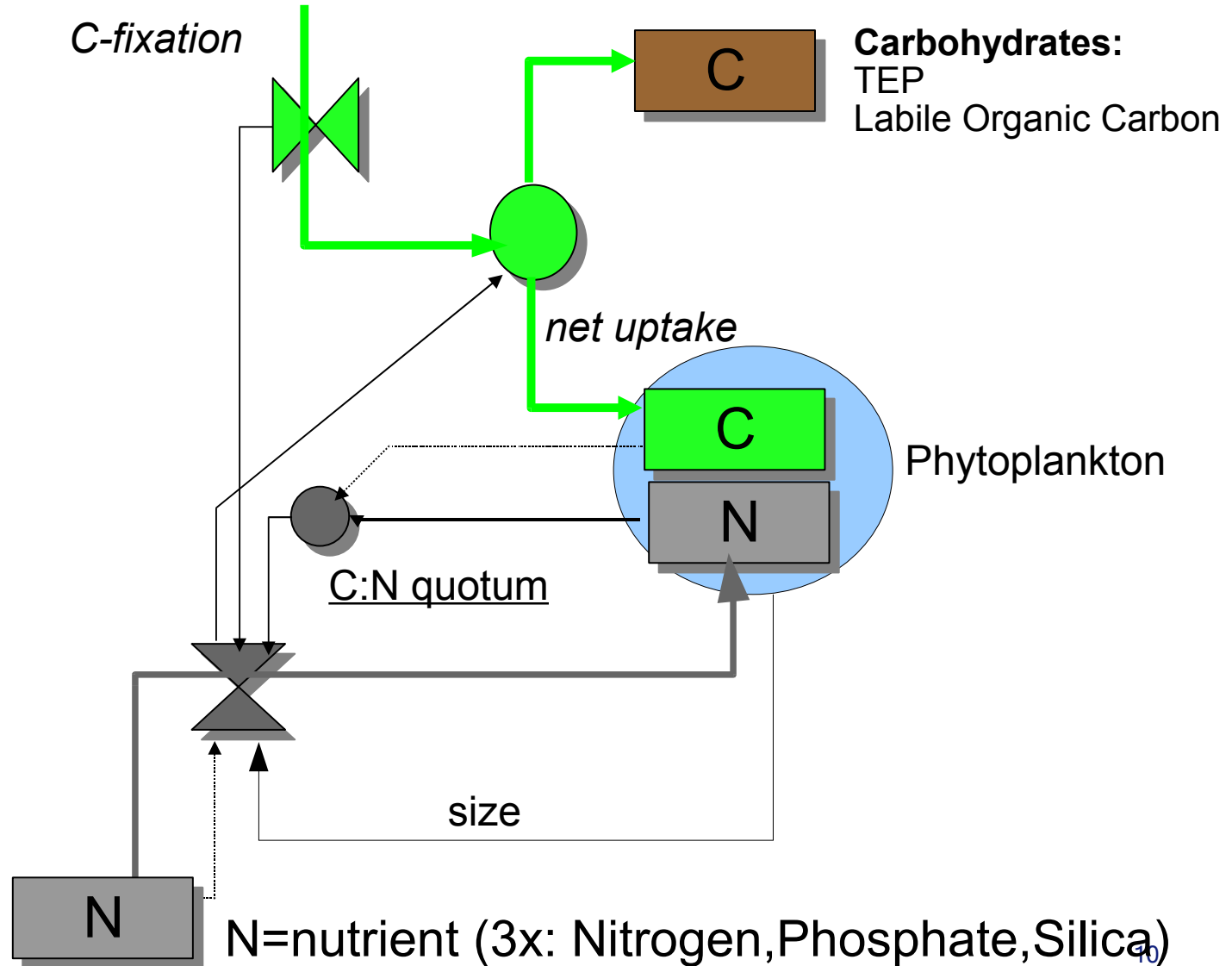

Benthic submodel of BFM (ERSEM)

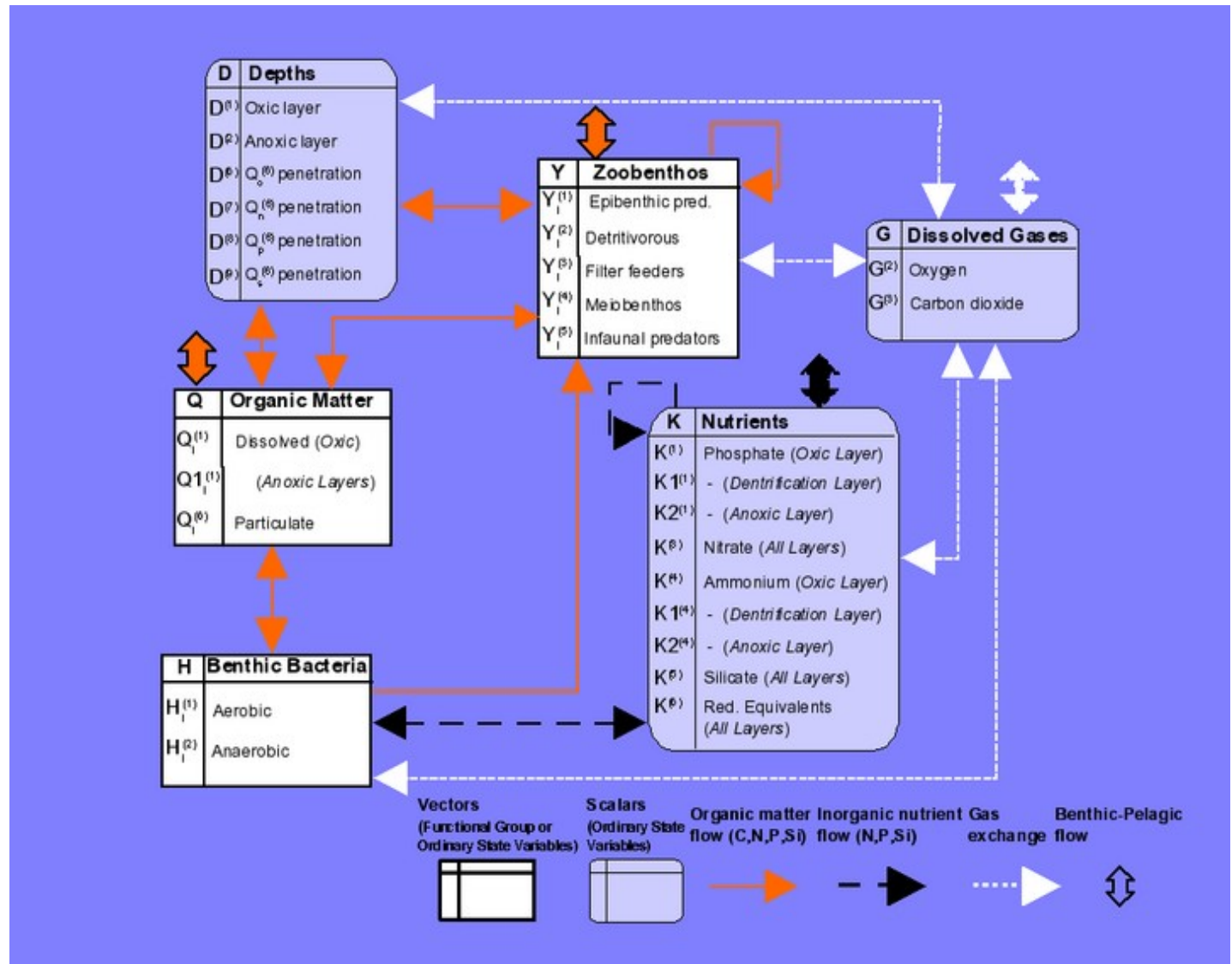

Benthic submodel: foodweb

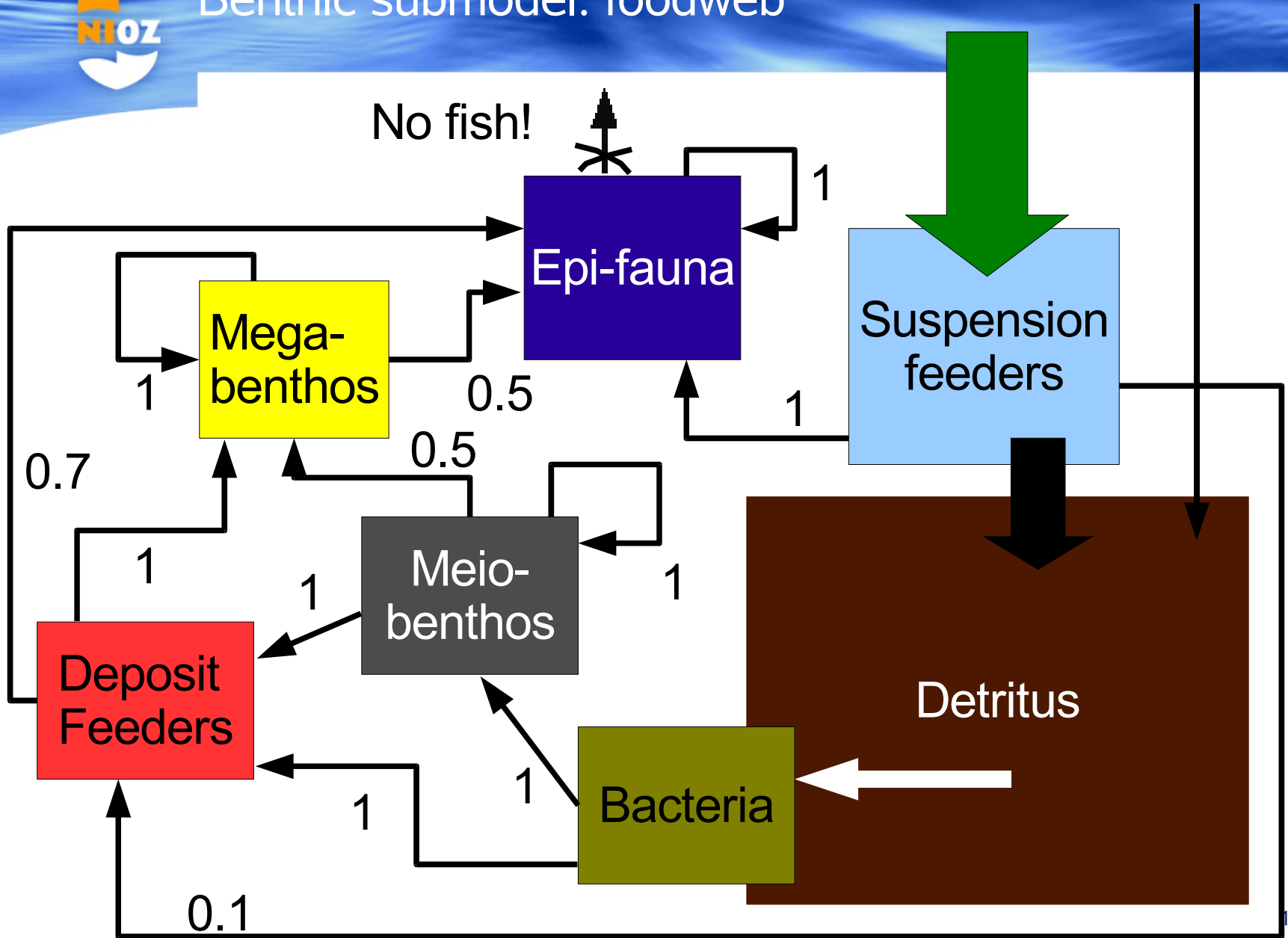



How we can use the model?

- Checking & testing
 - Check results (in 5 dimensions: x,y,z,t, state variables)
 - Validate model
 - Extend model if necessary:
- Budget Calculations
- Applications
 - Phosphate Input versus Zooplankton production
 - Calculation of potential food production for:
 - Pelagic fish
 - Demersal fish



Results:

- Output:
 - Phytoplankton (3d)
 - Nitrate(3d)
 - Filterfeeders(2d)



Testing: Modelled filterfeeder mass (mgCm^{-3}) with original ERSEM code

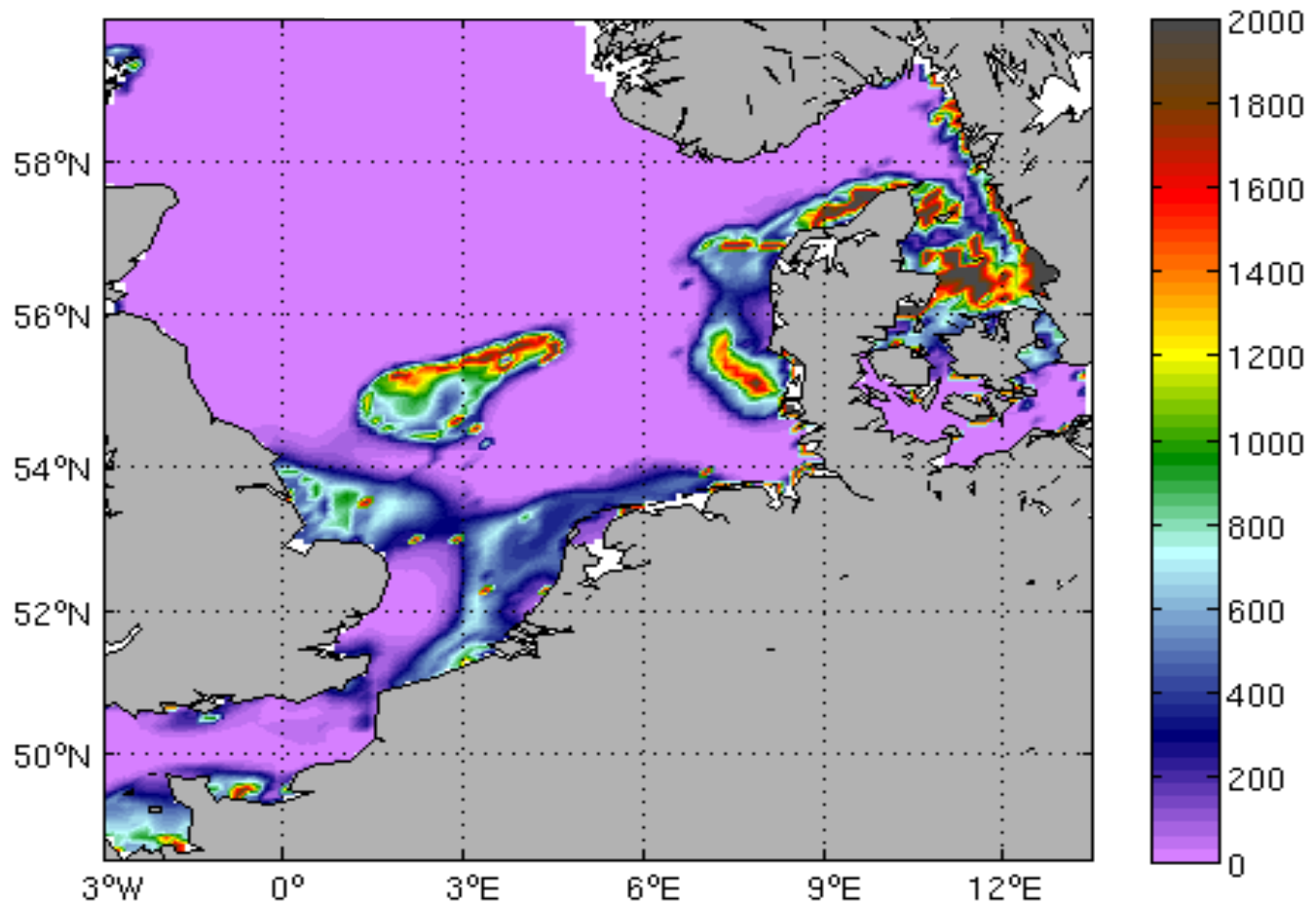



Observed
Filter feeder biomass
($\text{gAFDW} = 2.5 \cdot \text{gC}$)

**BIOMASS
g AFDW**

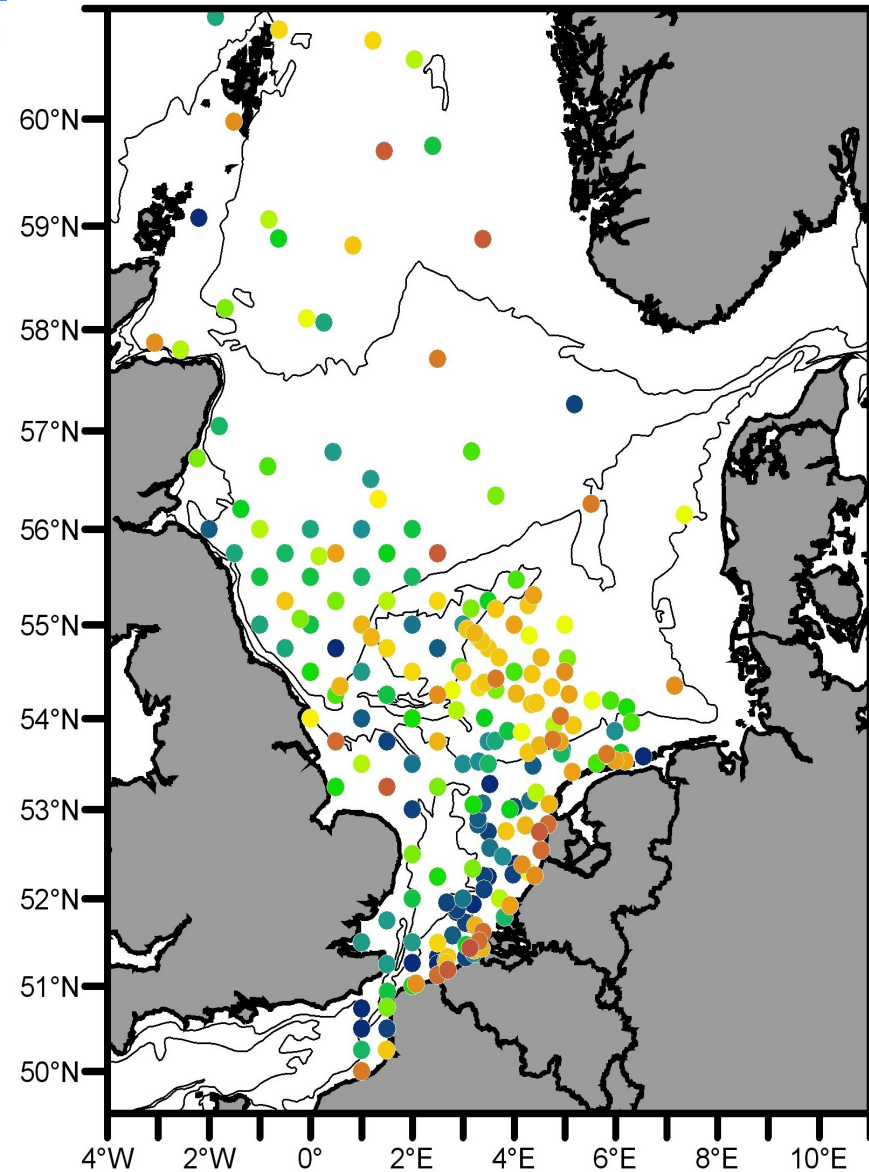
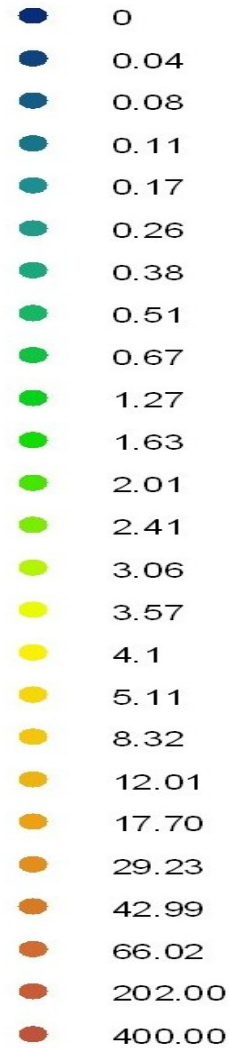



Testing: Modelled filterfeeder mass (mgCm^{-3}) with improved benthic-Pelagic coupling

Warning:
No fishery mortality in model!

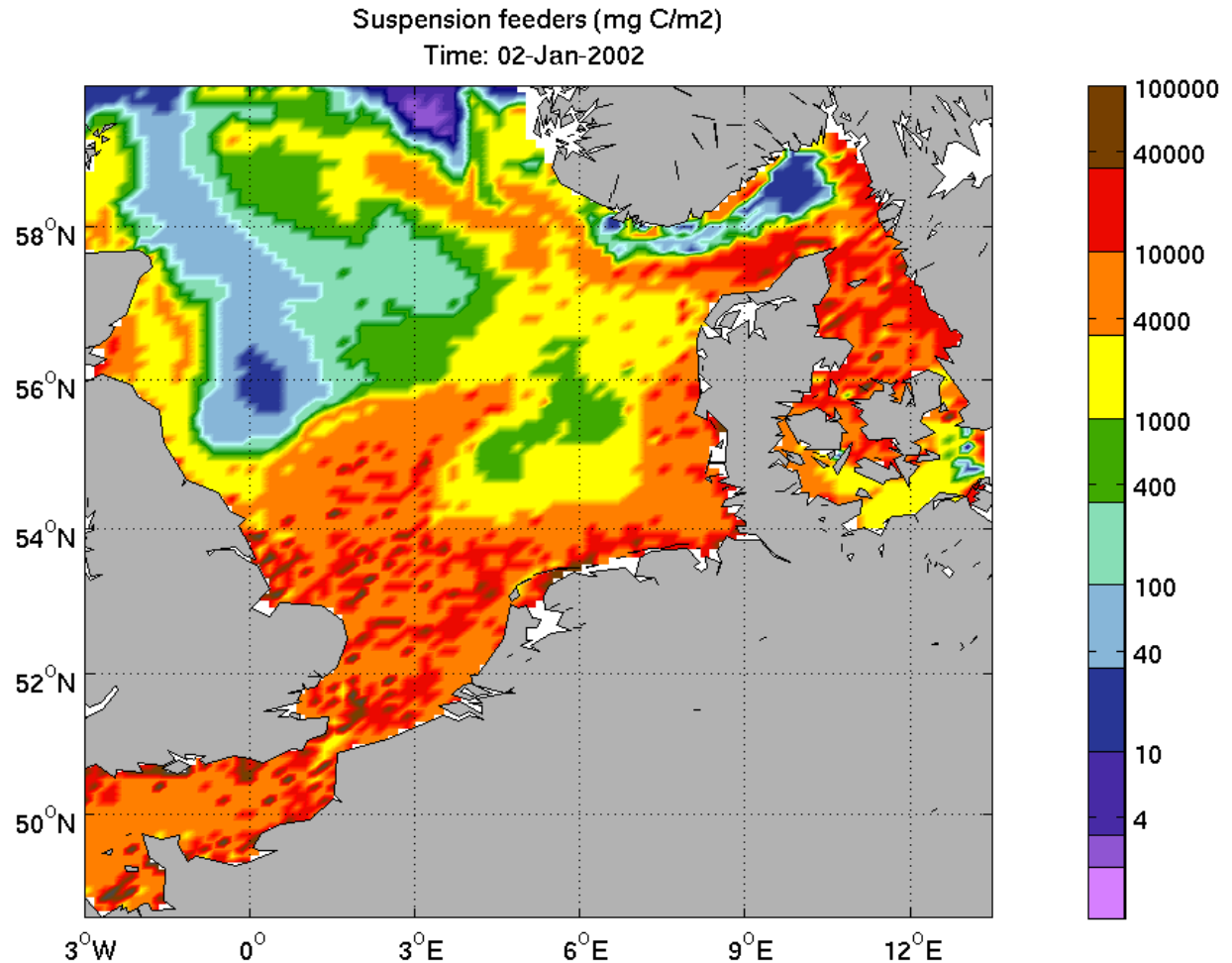



Improved benthic pelagic coupling

In 2 layer box-ERSEM model (1999) sedimentation of diatoms under nutrient depletion works:

- How? The biomass which arrive in the lower layer is directly available for food for the filter feeders

In 25 layer system (this model) diatoms sink until they arrive in a layer with nutrients and subsequently directly stop sinking.....

Further is important that diatoms:

- survive long periods in dark
- need to arrive in good shape near the sediment in order to feed the filter feeders



Aim : improvement of benthic-pelagic coupling ,
especially for columns > 40 meter

- Results with original eco-model in setup with hydrodynamical showed :
too low production of suspension feeder biomass in areas with depth
larger than 40m
- sedimentation controlled by nutrient depletion does not work for deep
water columns
- Therefore new concept:
 - diatoms excrete TEP under nutrient depleted circumstances
 - diatoms and TEP form macro-aggregates at high concentrations
and nutrient depletion
 - the removal of the macro-aggregates is mainly controlled by the
gravity:: fast sinking



TEP production by diatoms

Assumptions:

- Under nutrient depletion excrete all new fixated Carbon, which can not be used for growth are excreted as TEP:
 - gross prim. prod : $P_C(l)$
 - nutrient uptake: $u_N(N) = \eta N P_C$
 - TEP production:
$$p_{TEP} = p_C(l) - \frac{(u_N + \alpha * (P_N - P_C * q_{NC}^l))}{q_{NC}^l}$$
- TEP is sticky and induces formation macro-aggregates consisting of phytoplankton, TEP and detritus.
- Macro-aggregates sinks to the sediment depending on the concentrations of diatoms, TEP and detritus.
- The macro-aggregates are implicitly modelled: there are parameters defined for maximum sinking rates and an "stickiness" which determines the actual velocity for the combinations TEP-TEP, TEP-diatoms and TEP-detritus.

Filterfeeder: in/output

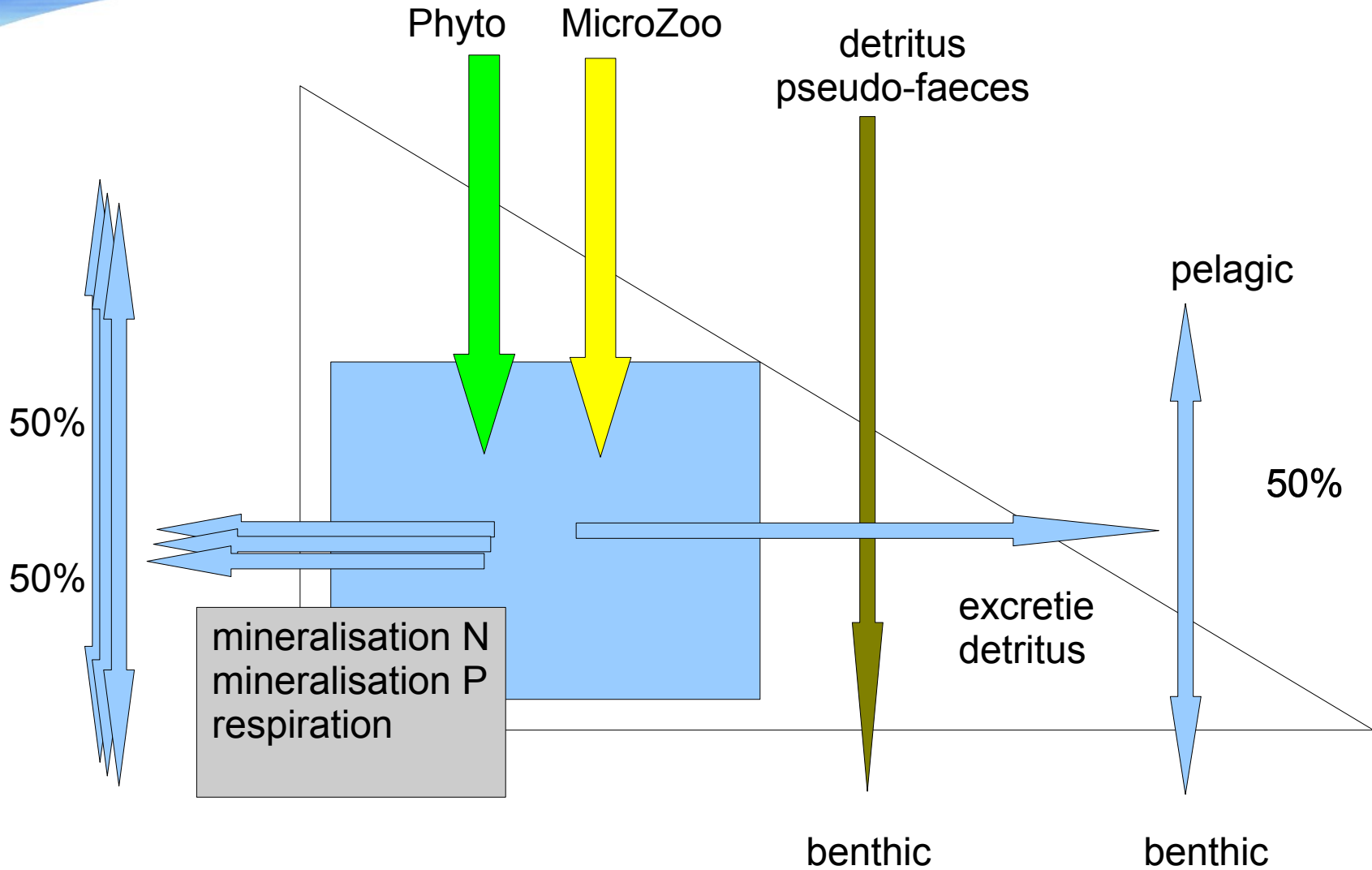



Testing of new code:

- Use a one-column model with realistic METEO forcing.
- Test the new code for columns with different depths
- Make a closed system. All N removed by denitrification is assumed directly be returned as input from the air.
- Make long runs: filterfeeders are slow growers
- We started to test the code for a column of **80 meter**: there is the input of more food highly needed.



Results 1D-model column 80m: suspension feeders, epibenthos, deposit feeders

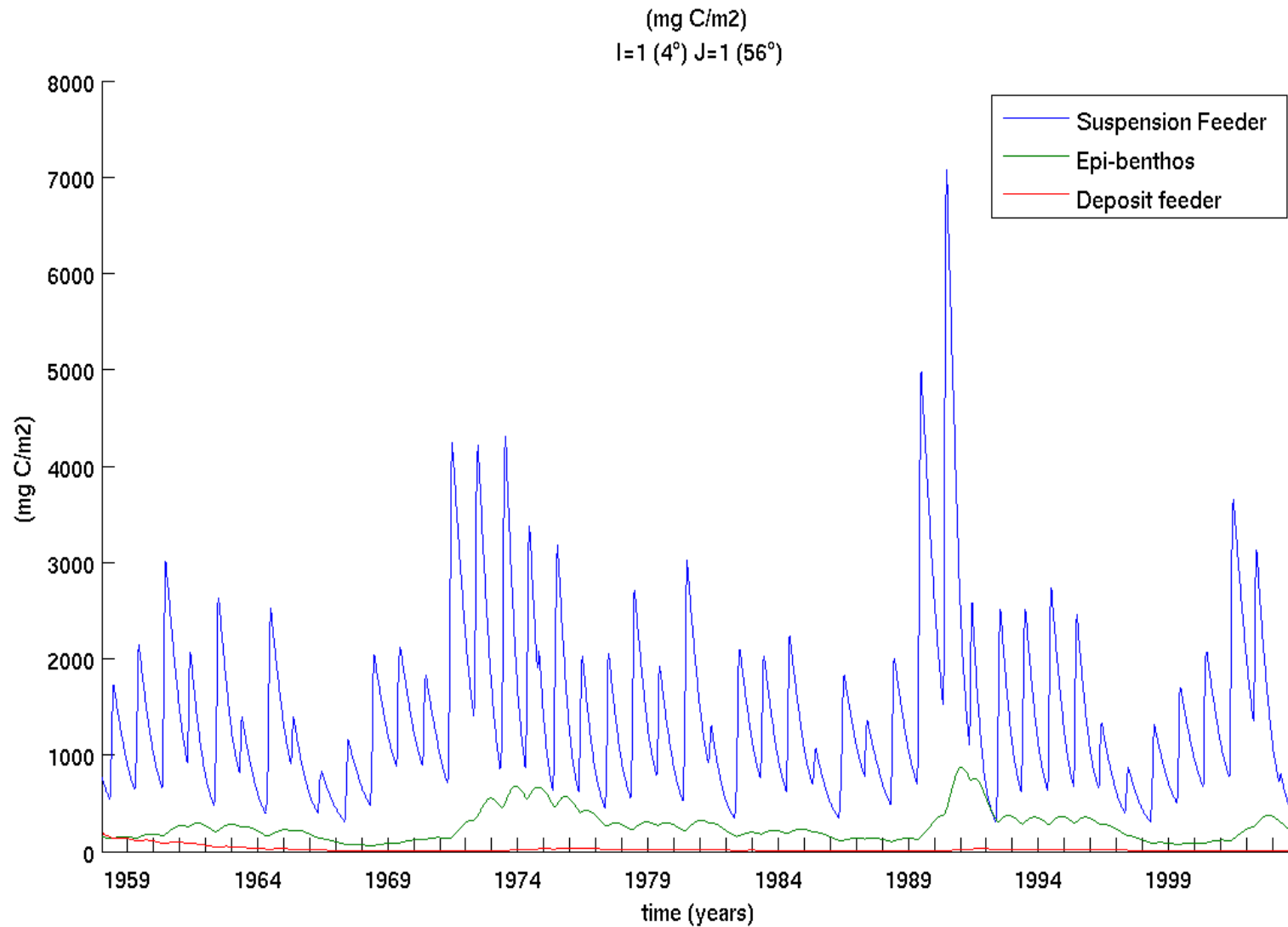



Results 1D-model column 80m: Net Prim. Prod (mgC m⁻² d⁻¹)

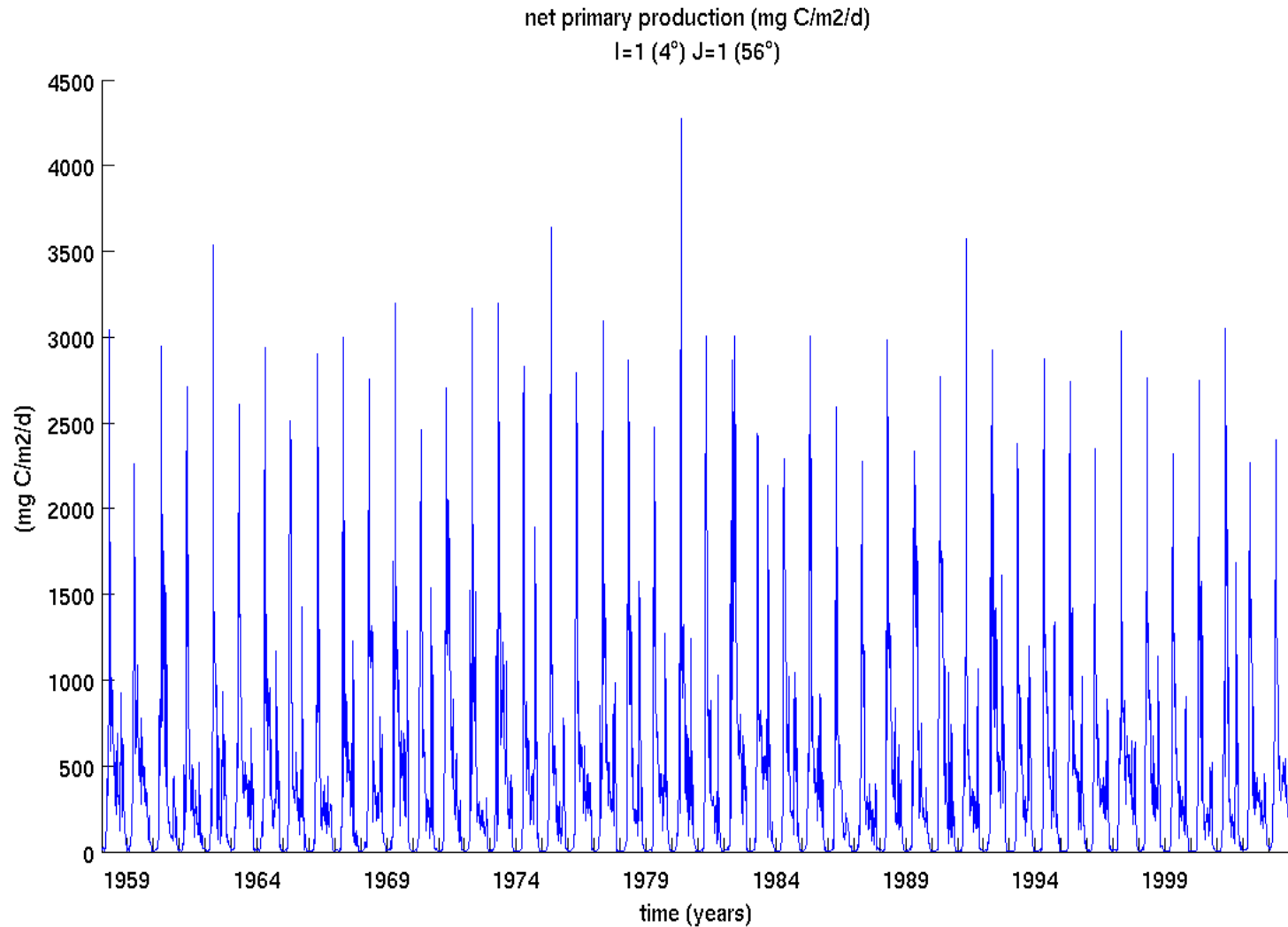



Input of phytoplankton to intermediate layer between pelagic and benthos.

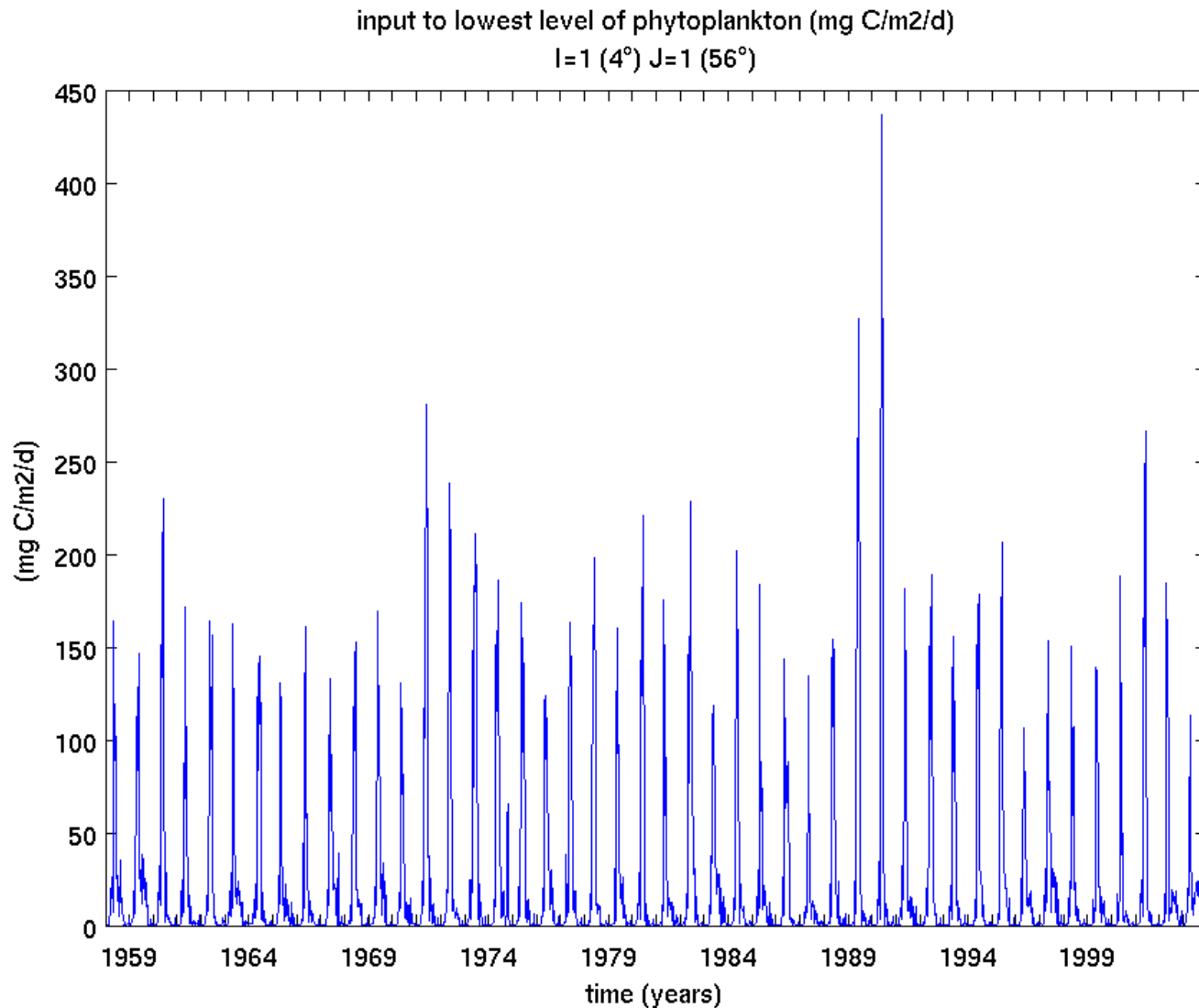



Results 1D-model column 80m: Chlorophyll (mg C m^{-3})

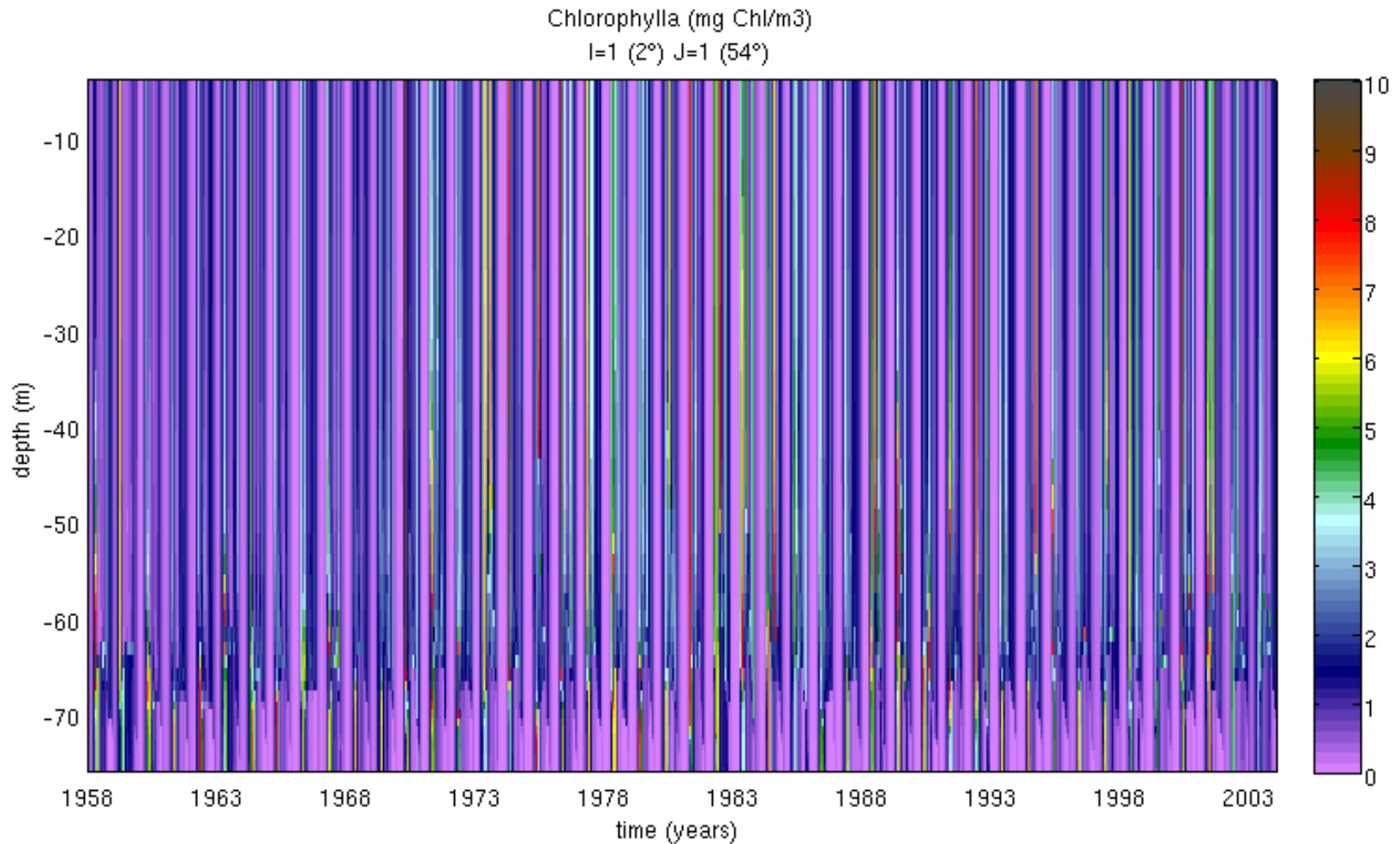



Results 1D-model column 80m: Chlorophyll (mg C m^{-3})

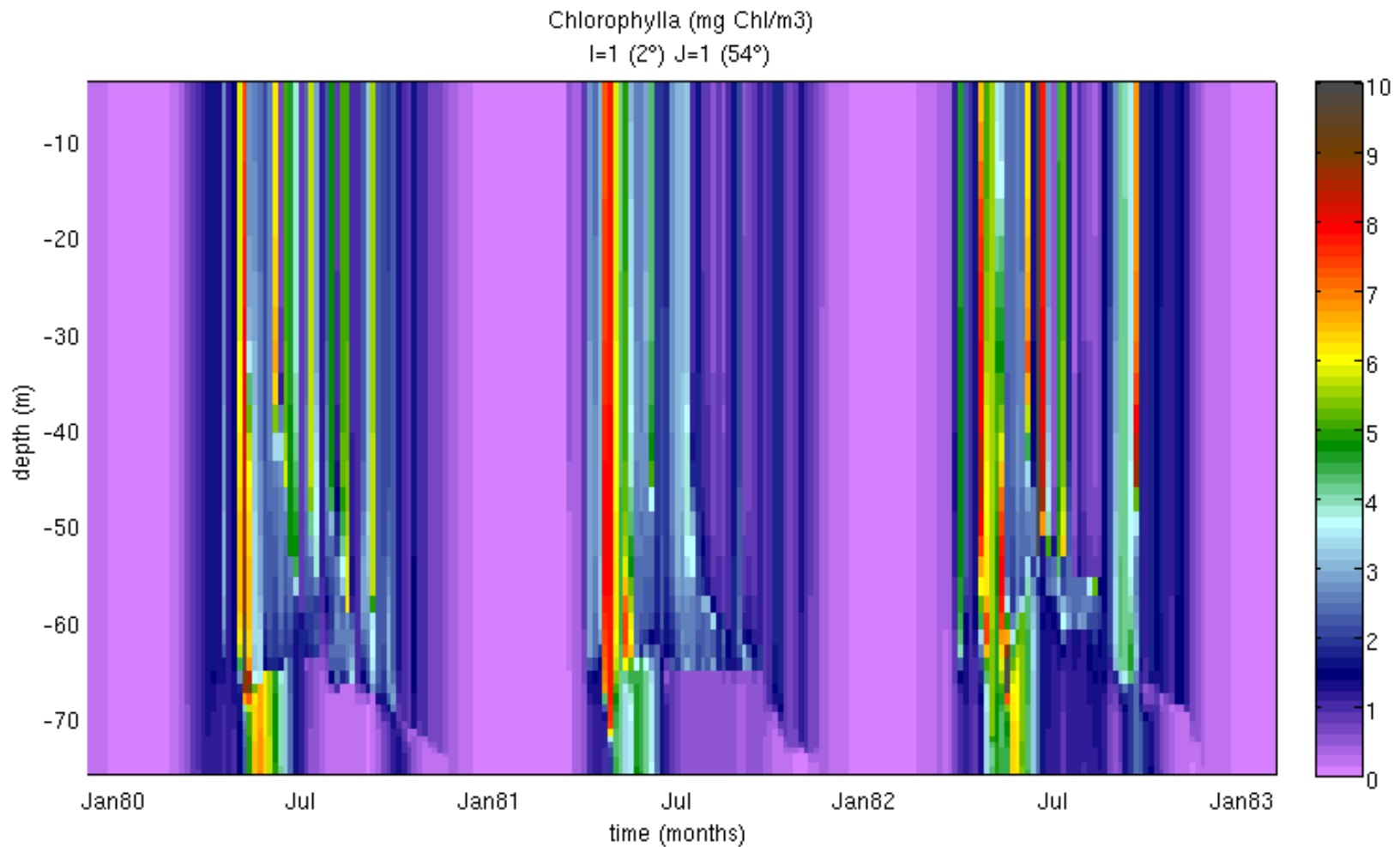



Results 1D-model column 80m: TEP (mg C m⁻³)

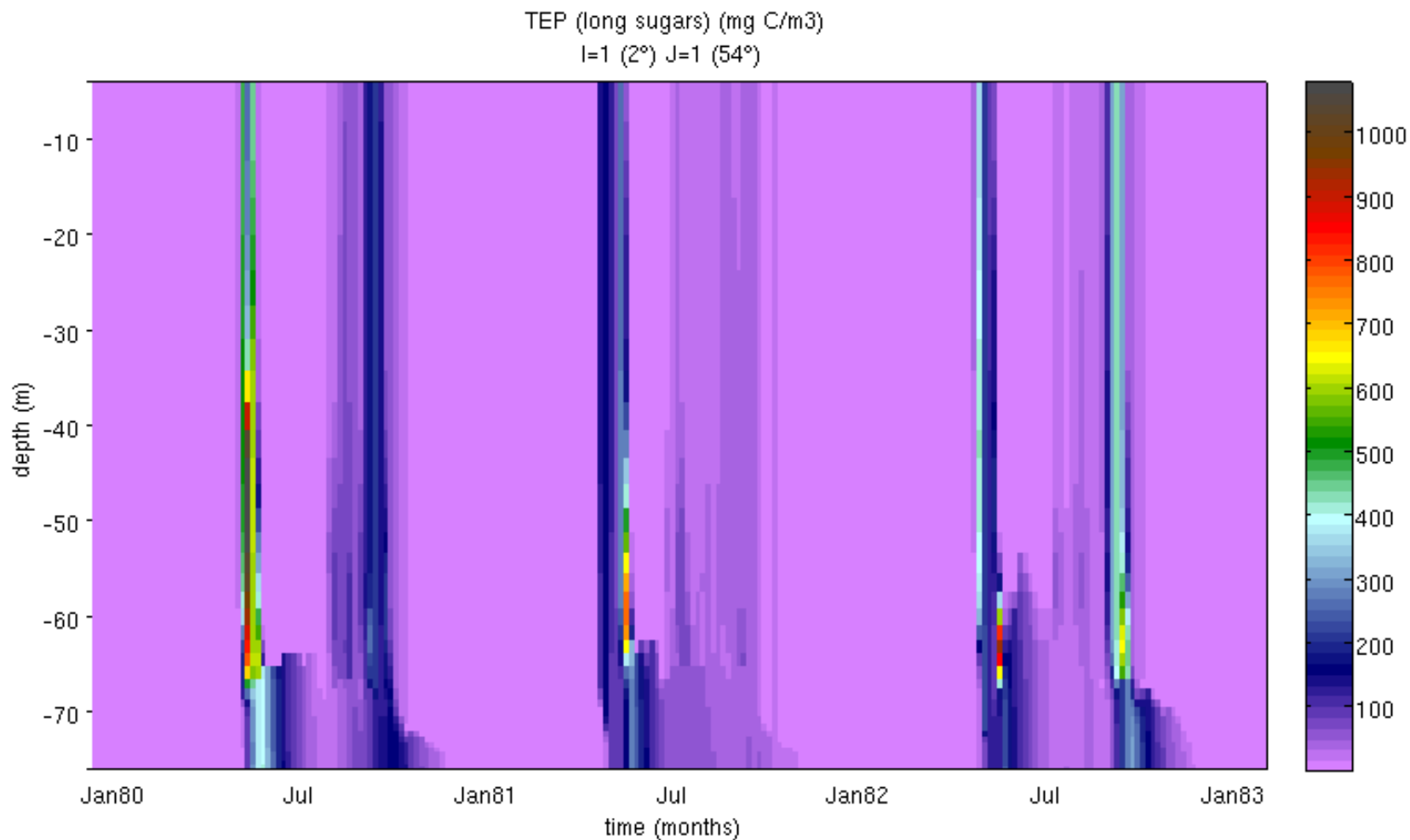



Sedimentation rate of diatoms (m d^{-1})

P1(PhytoPlankton) sedimentation rate (m/d)
I=1 (2°) J=1 (54°)

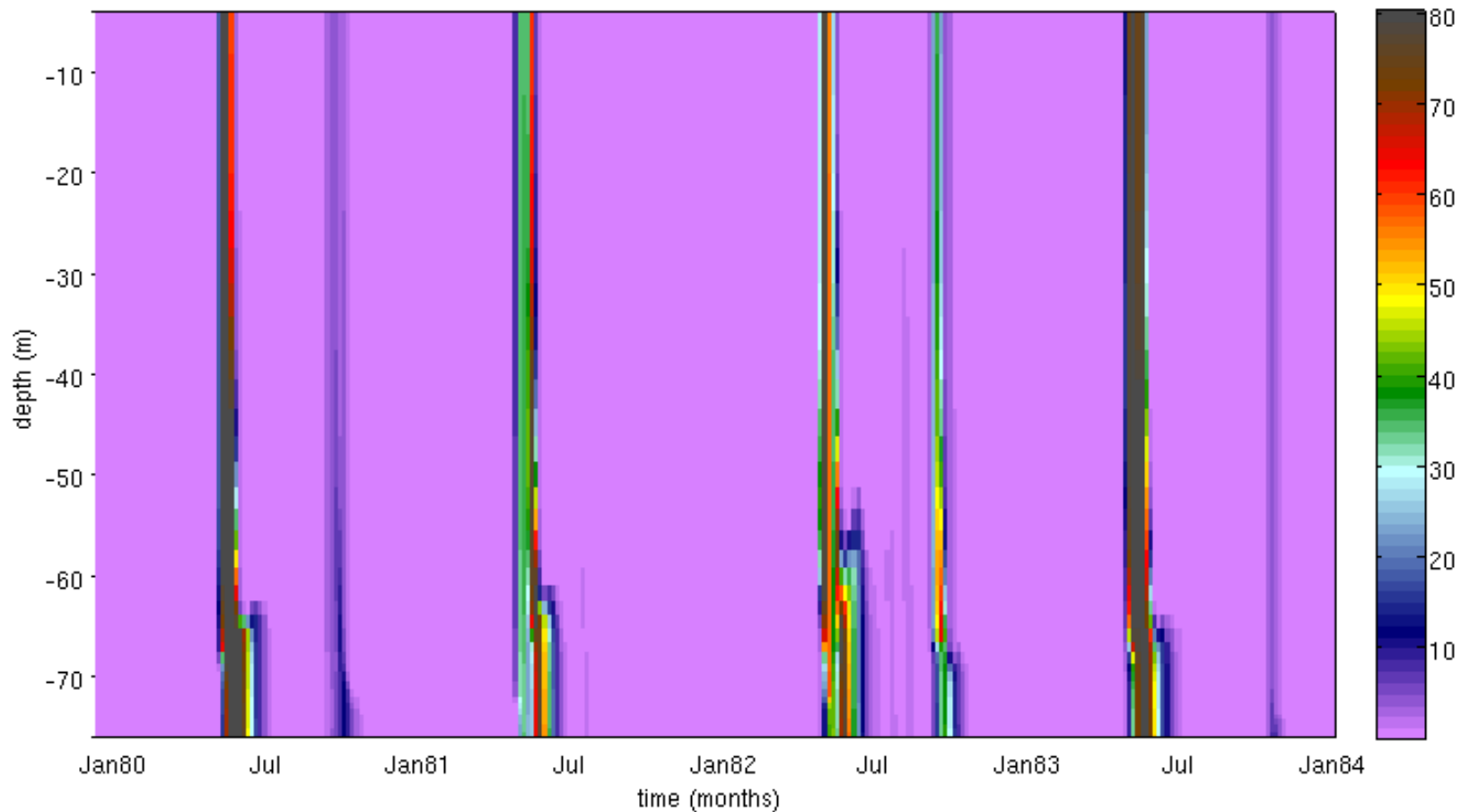



How to explain the dynamics of the filter feeders?

Problem to understand the dynamics:

- Slow changes in the dynamics in benthos
- Biomass is not “reset” every winter.

How?

- determine the equilibrium situation:
- make it possible to do a many-year run in which for each year the same meteo input is used.
- keep losses for N and P zero.

Therefore: 50 long runs (50 years) made

- in which the meteo-input of one year repeatedly used
- resulting in 50 runs with the sequence number the year which is used for the run

Example of “equilibrium run” : suspension feeders(mg C m^{-3})

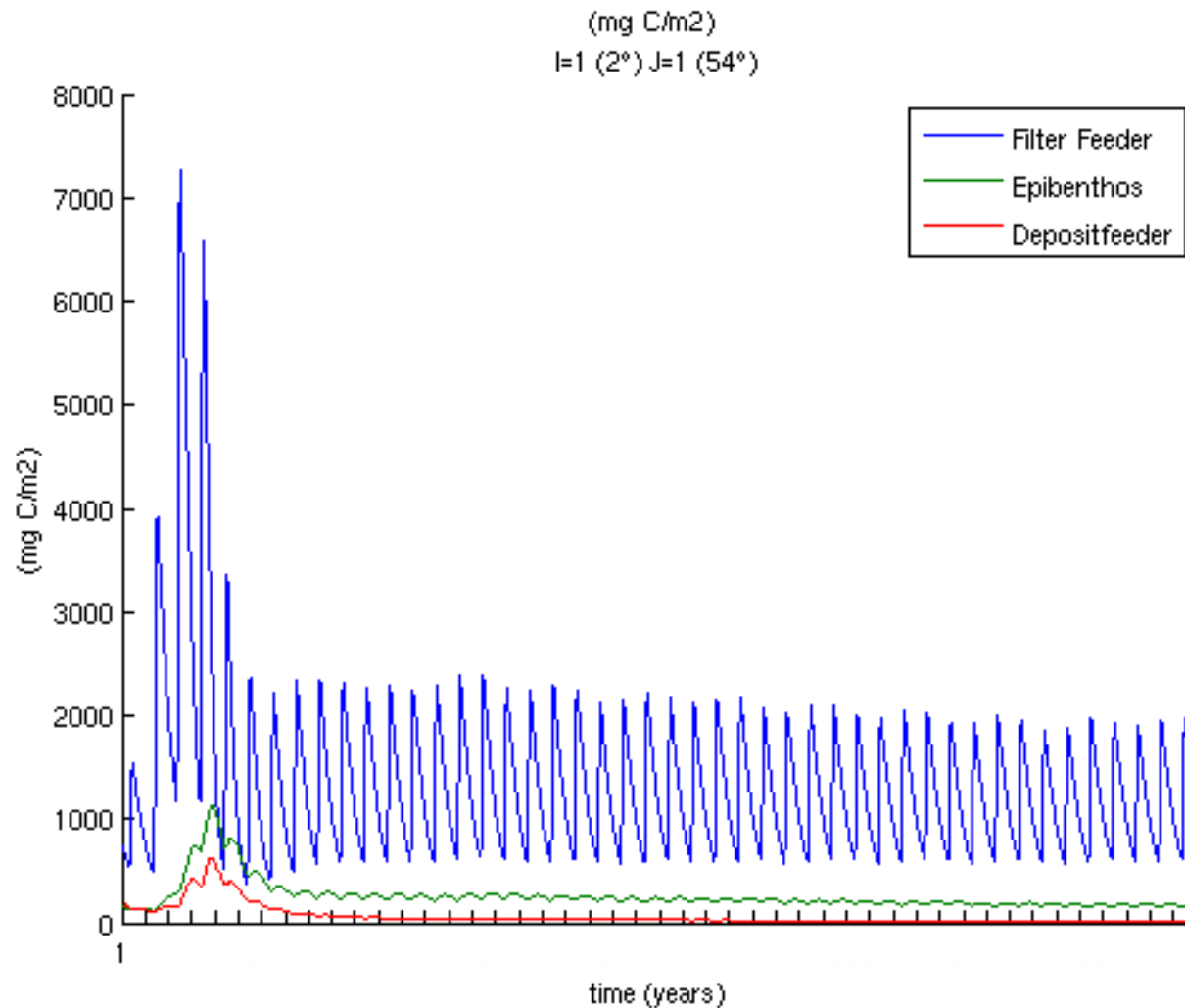



Summary of results: average concentration for every run of suspension feeders (mg C m^{-3})

Filter feeders

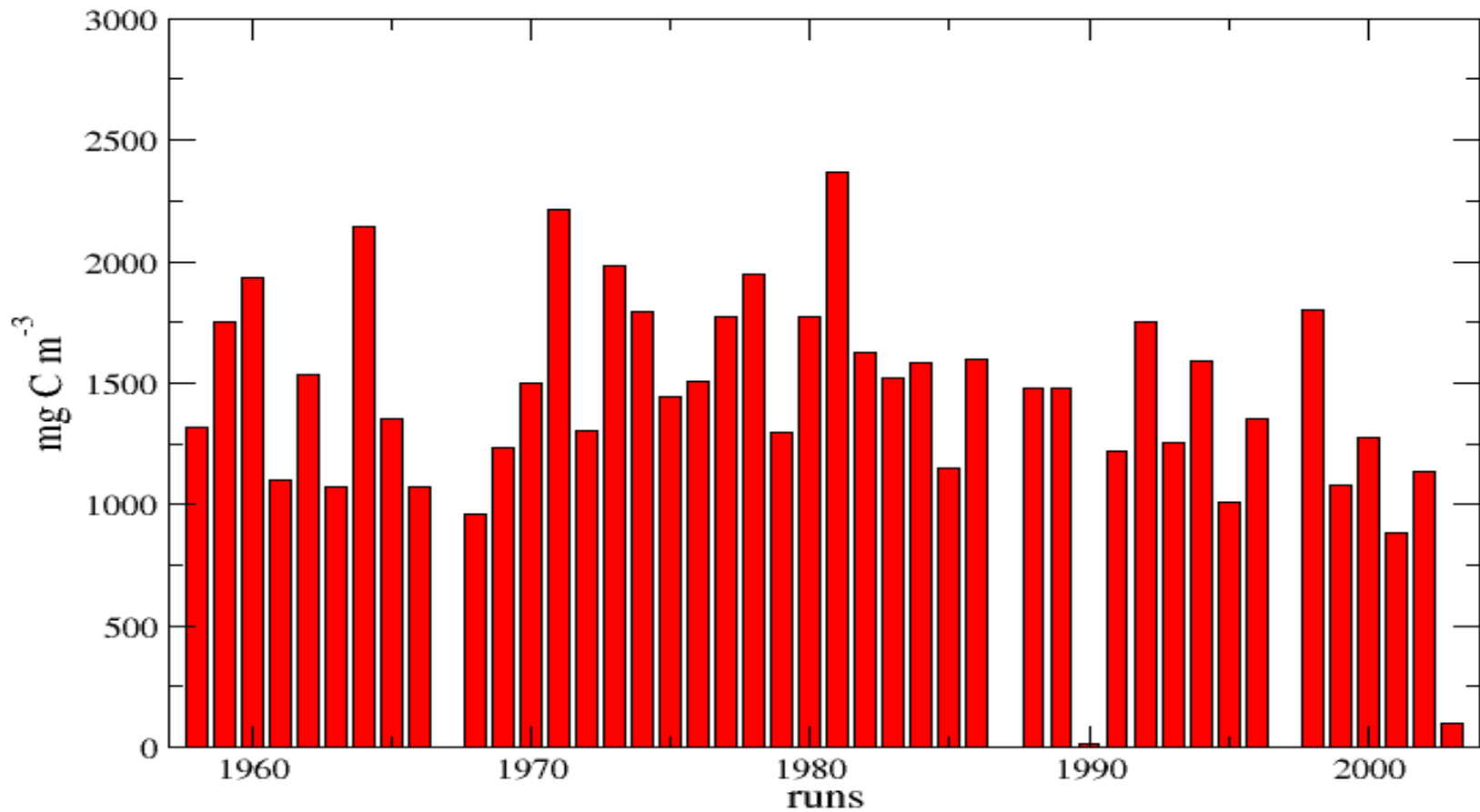



net specific growth (d^{-1}) =
net specific food uptake - maintenance respiration

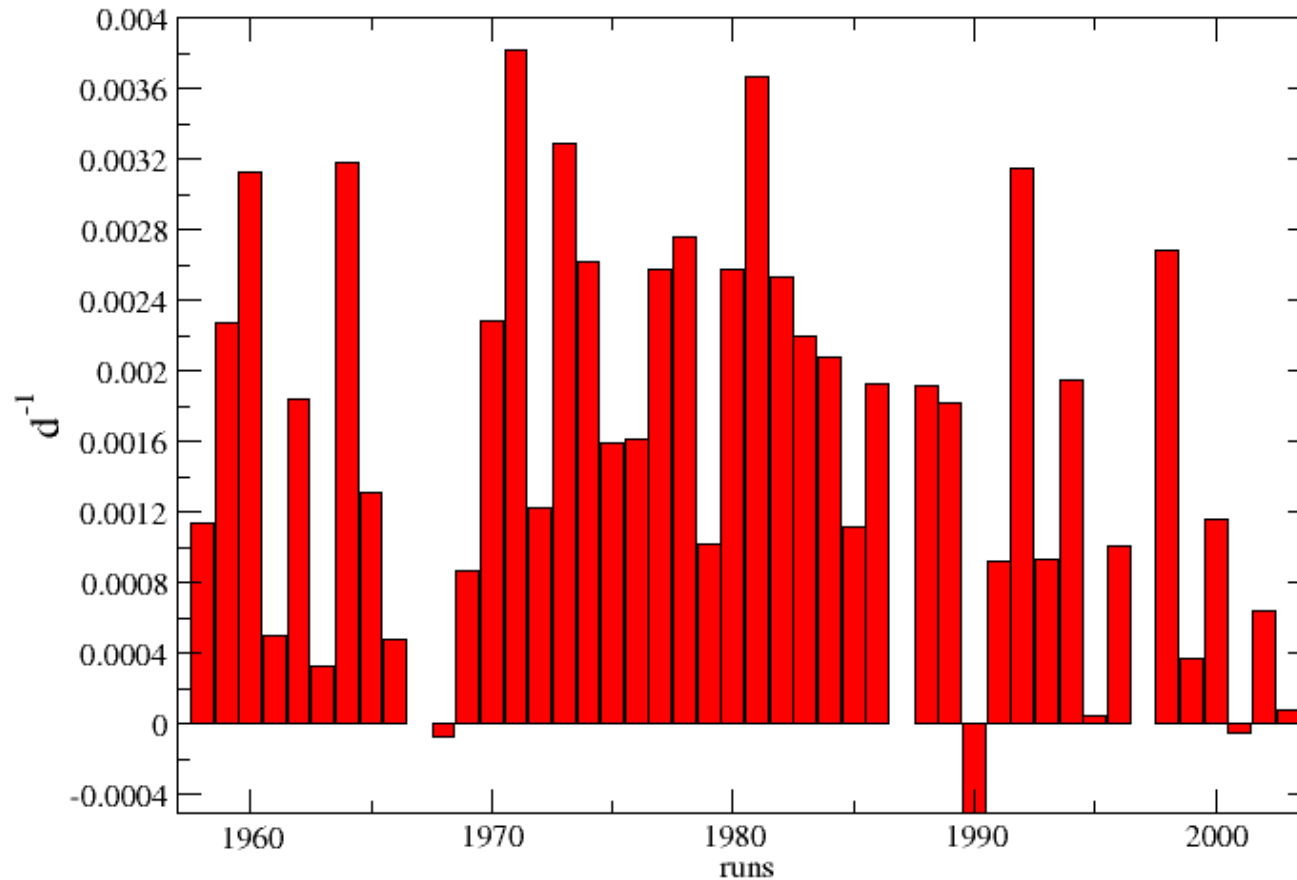



The relation between phosphate input from the Rhine and fish production in the Dutch coastal zone

- The Dutch government asked IMARES to test with existing models how much phosphate should be inputted/added in the Rhine to get an increase of the fish production with 10% in the Dutch coastal zone.
- The idea by the fisheries that the decrease of the phosphate input from the Rhine was the cause for the lower fish production in the last 10 years.
- It was tested by Bert IMARES for the Western Wadden sea and by the NIOZ for the NorthSea.
- We took as indicator for the fish production the secondary production of zooplankton .



Setup:

- The so-called “standard run” is done for the period February-June in 1998:
 - all forcing (meteorological, boundaries and river input are based on measured data in 1998)
 - It is expected that changes in nutrient loading from the rivers has the largest impact in this period.
 - Initial values are derived from a 13 months run for the period January 1997-February 1998
- The results of this run are compared with 2 sensitivity-analysis runs:
 - A run with 45% of the phosphate loading in 1998. (= the load of 2006).
 - A run with 197% of the phosphate load in 1998, (= the highest observed phosphate load)



Rhine:

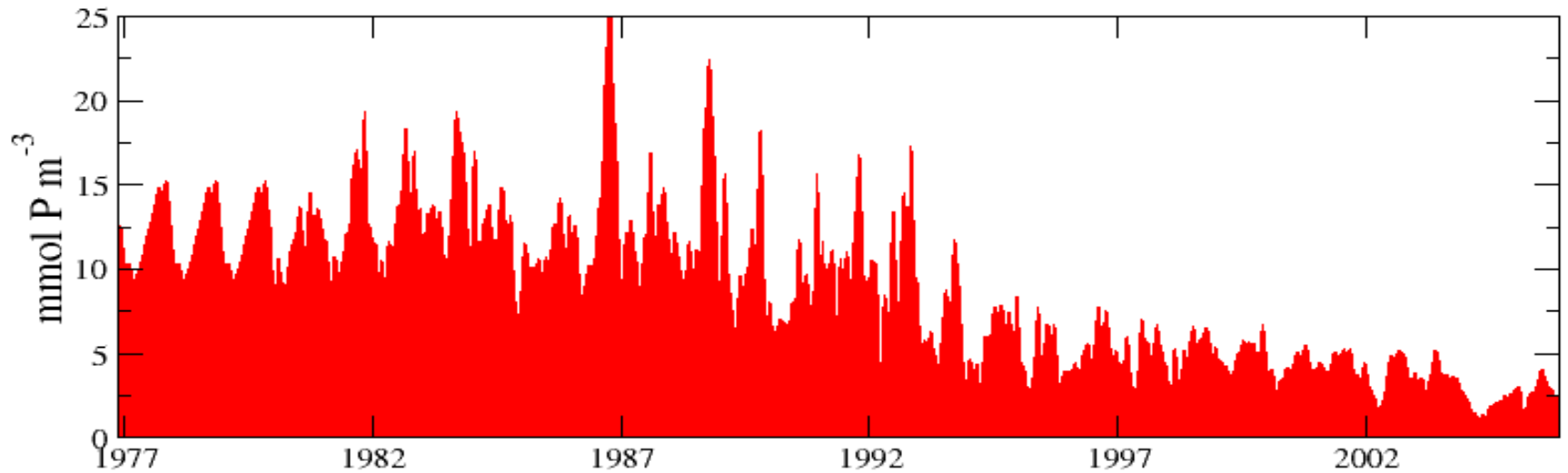
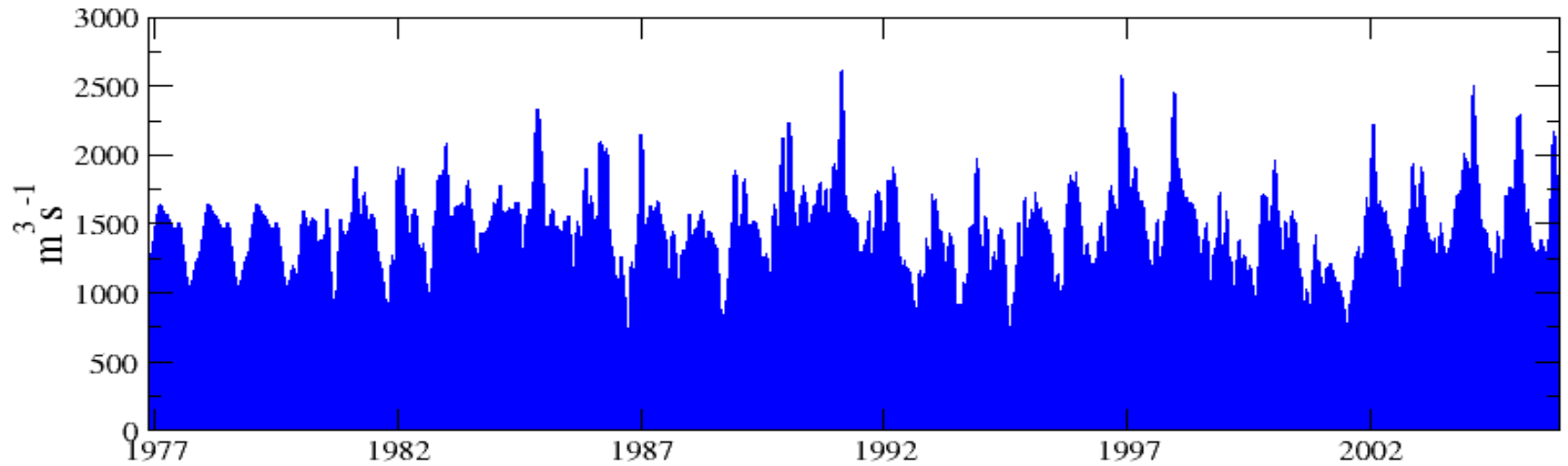



PO_4^{3-} input:
582 kmol $\text{PO}_4^{3-}[\text{P}] \text{d}^{-1}$

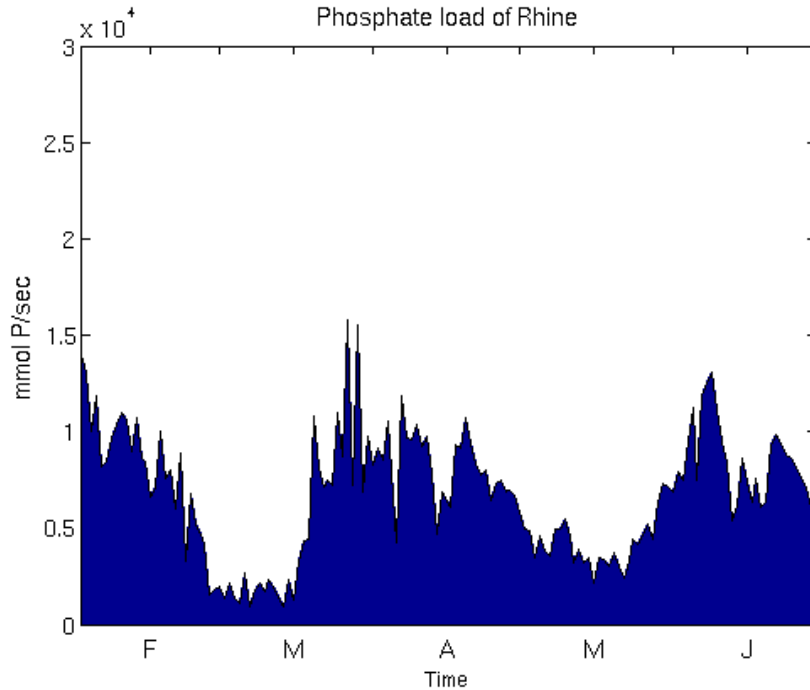

Standard run

Simulations Period:
Period February-June 1997

PO_4^{3-} input:
1146 kmol $\text{PO}_4^{3-}[\text{P}] \text{d}^{-1}$

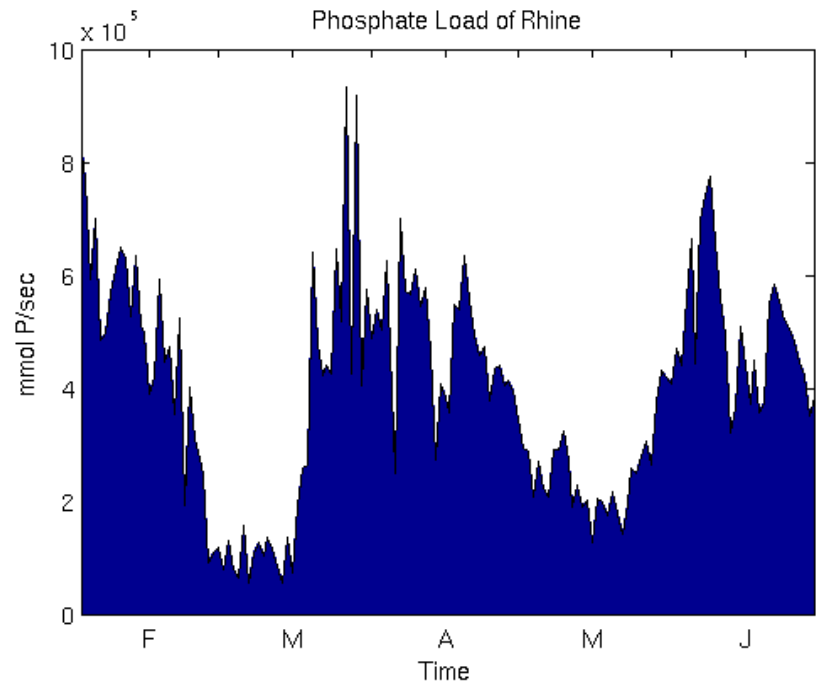

Run with Phosphate input of the
Rhine valid for 1985
Simulation Period:
Period February-June 1997



Standard run

Simulations Period:

Period February-June 1997

net second. mesoz. prod. (mgC/m²/d)
Time = ave(32,181) Ave/GridPoint=128.0433

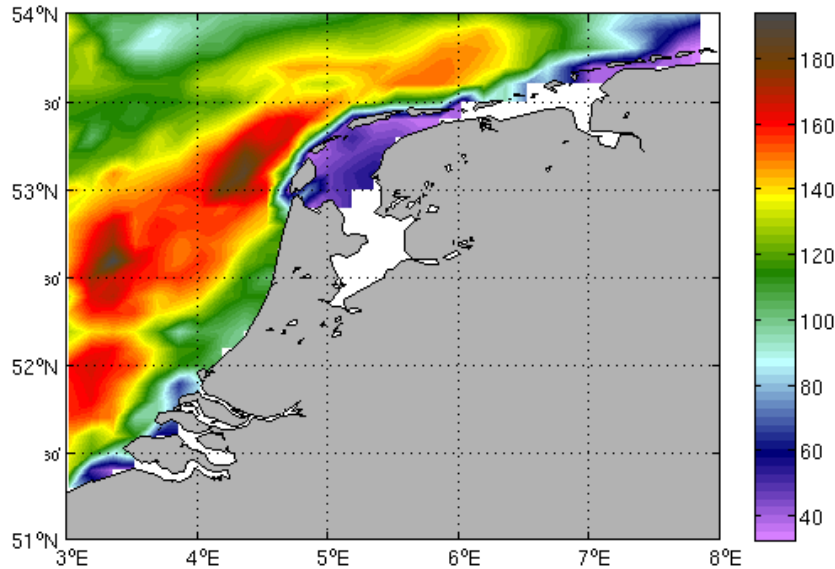

Secondary zooplankton
production: 128 mg C/m²/d
averaged over the (wet) area shown

Run with 1985 Phosphate input of the
Rhine.

Simulation Period:

Period February-June 1997

net second. mesoz. prod. (mgC/m²/d)
Time = ave(32,181) Ave/GridPoint=135.9467

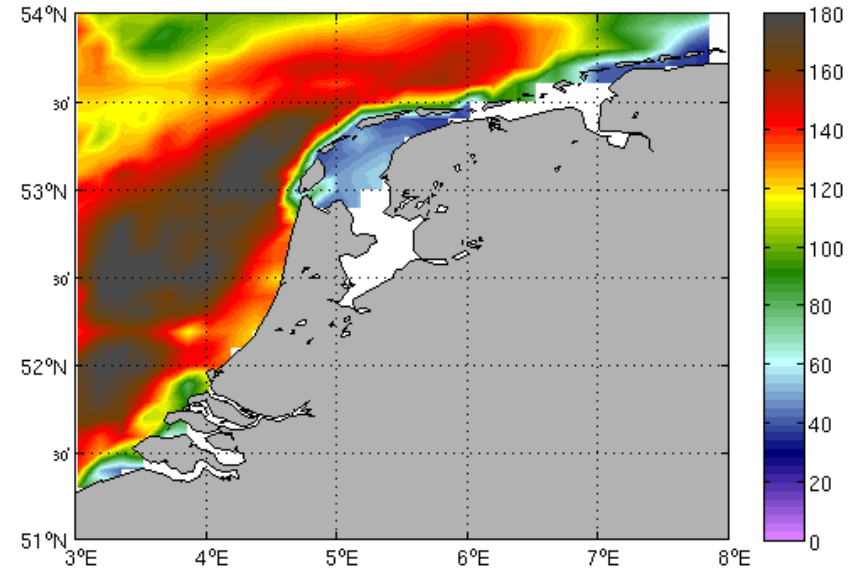

Secondary zooplankton
production: 136.5 mg C/m²/d
averaged over the (wet) area shown



Area of investigation is too large?

Standard run

Simulations Period:
Period February-June 1997

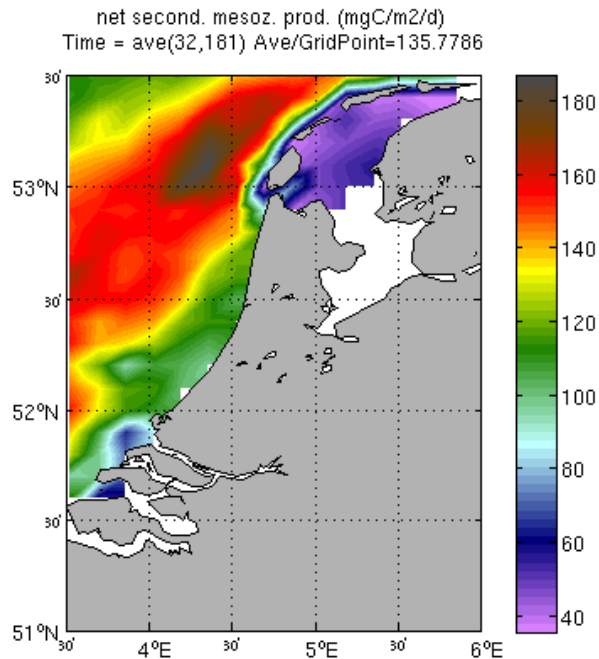

Secondary production: 135 mg C/m²/d
averaged over the (wet) area shown

Run with 1985 Phosphate input of the Rhine.

Simulation Period:
Period February-June 1997

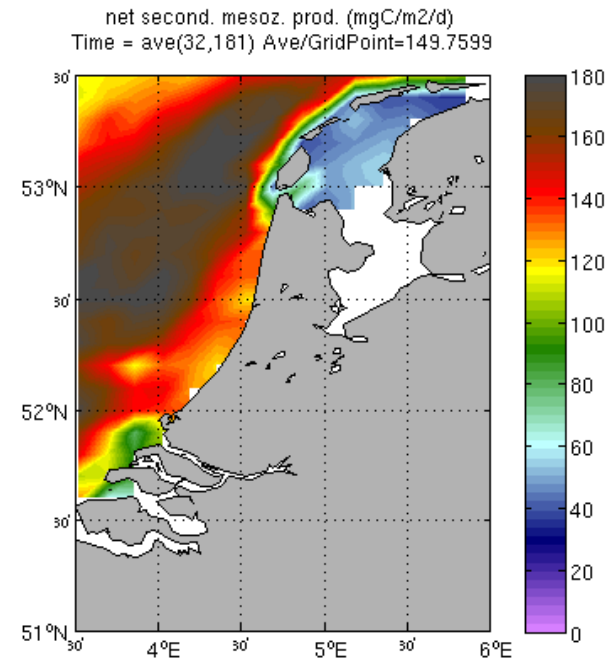

Secondary production: 149 mg C/m²/d
averaged over the (wet) area shown



Conclusion:

ZP ($\text{mgC m}^{-2}\text{d}^{-1}$)

Relation between Zooplankton production in kuststrook and Phosphate input van de Rhine

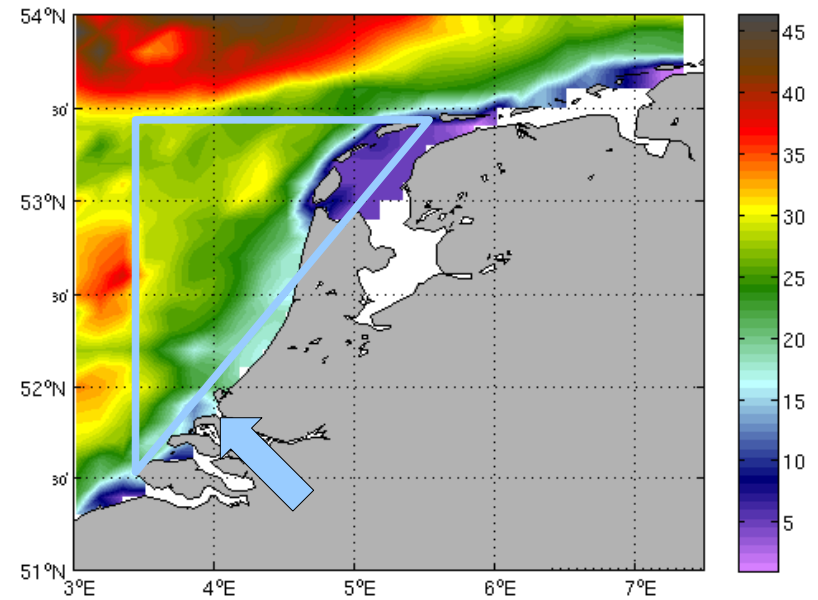
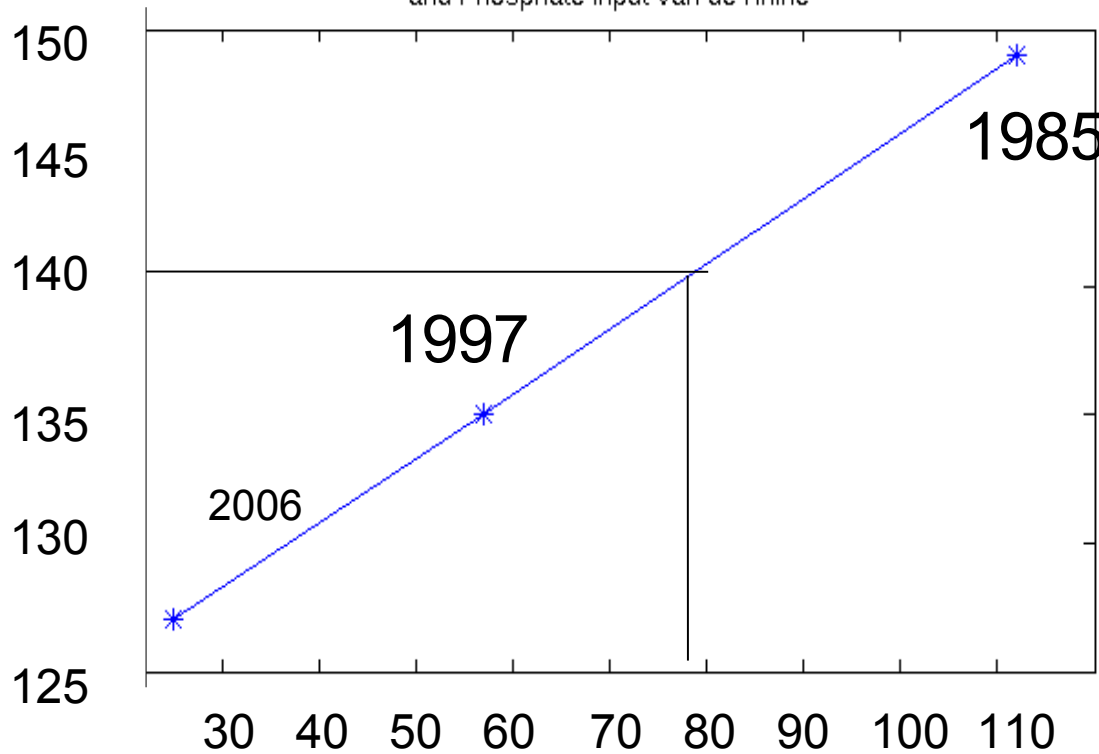



Spatial year Budgets of the different trophic levels as calculated with the model

Primary production versus bacterial production

Nett prim. prod ($200 \text{ g C m}^{-2} \text{ y}^{-1}$):

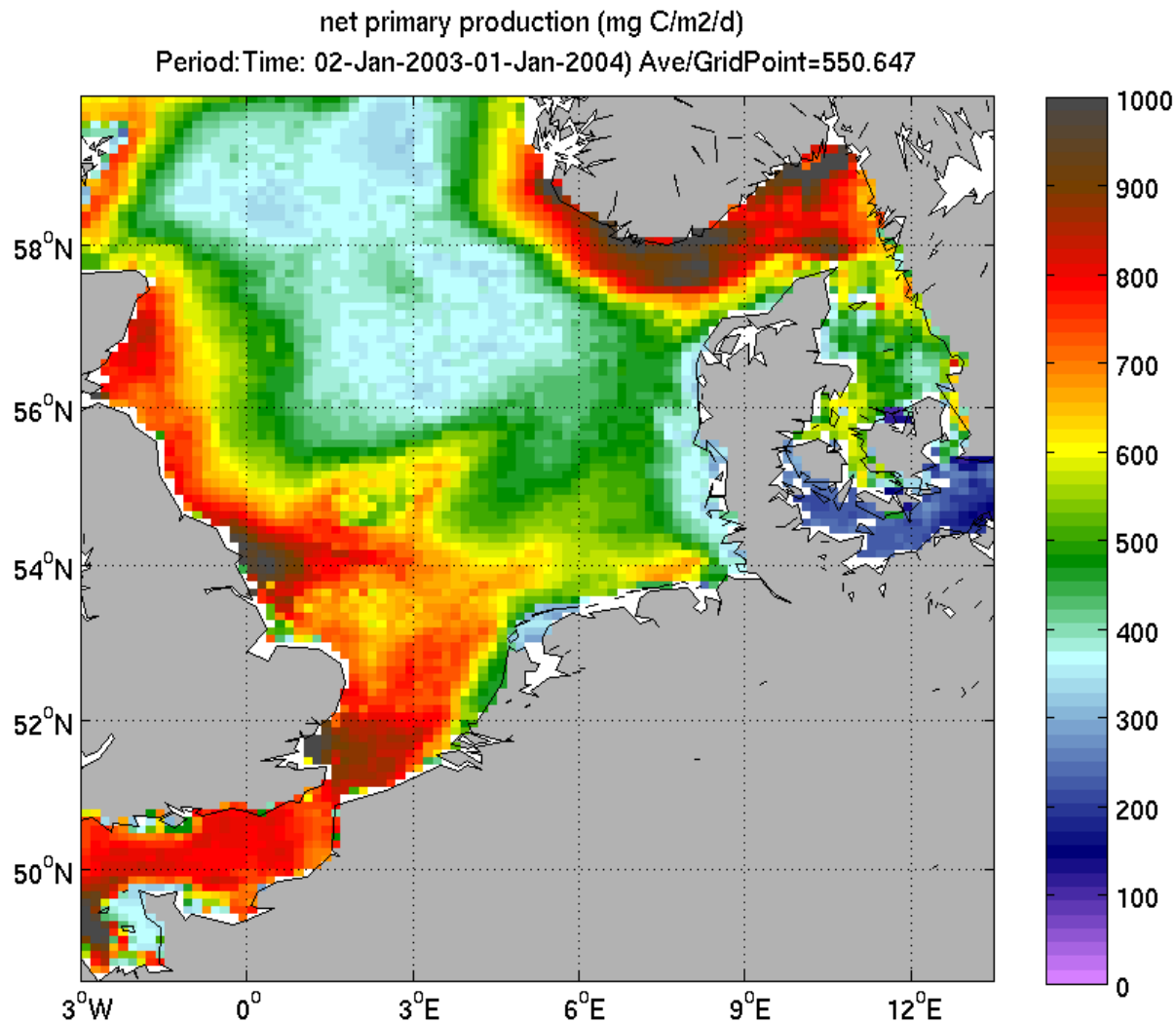

Netto bact. production ($116.5 \text{ gC m}^{-2} \text{ y}^{-1}$)

area_wide bact. production \ll net prim. prod.

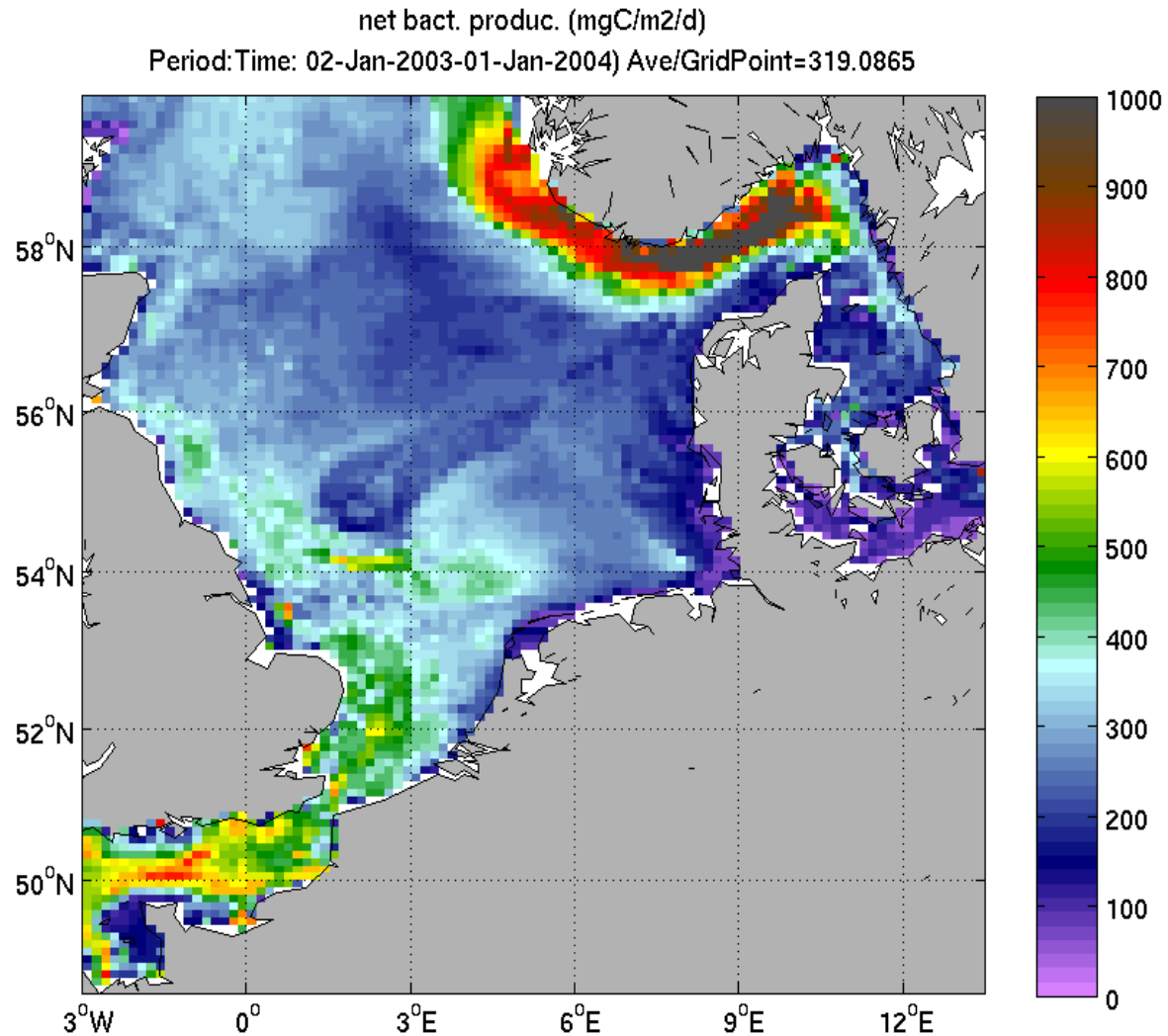



Net. mesozoo production : $16.7 \text{ gr m}^{-2}\text{y}^{-1}$

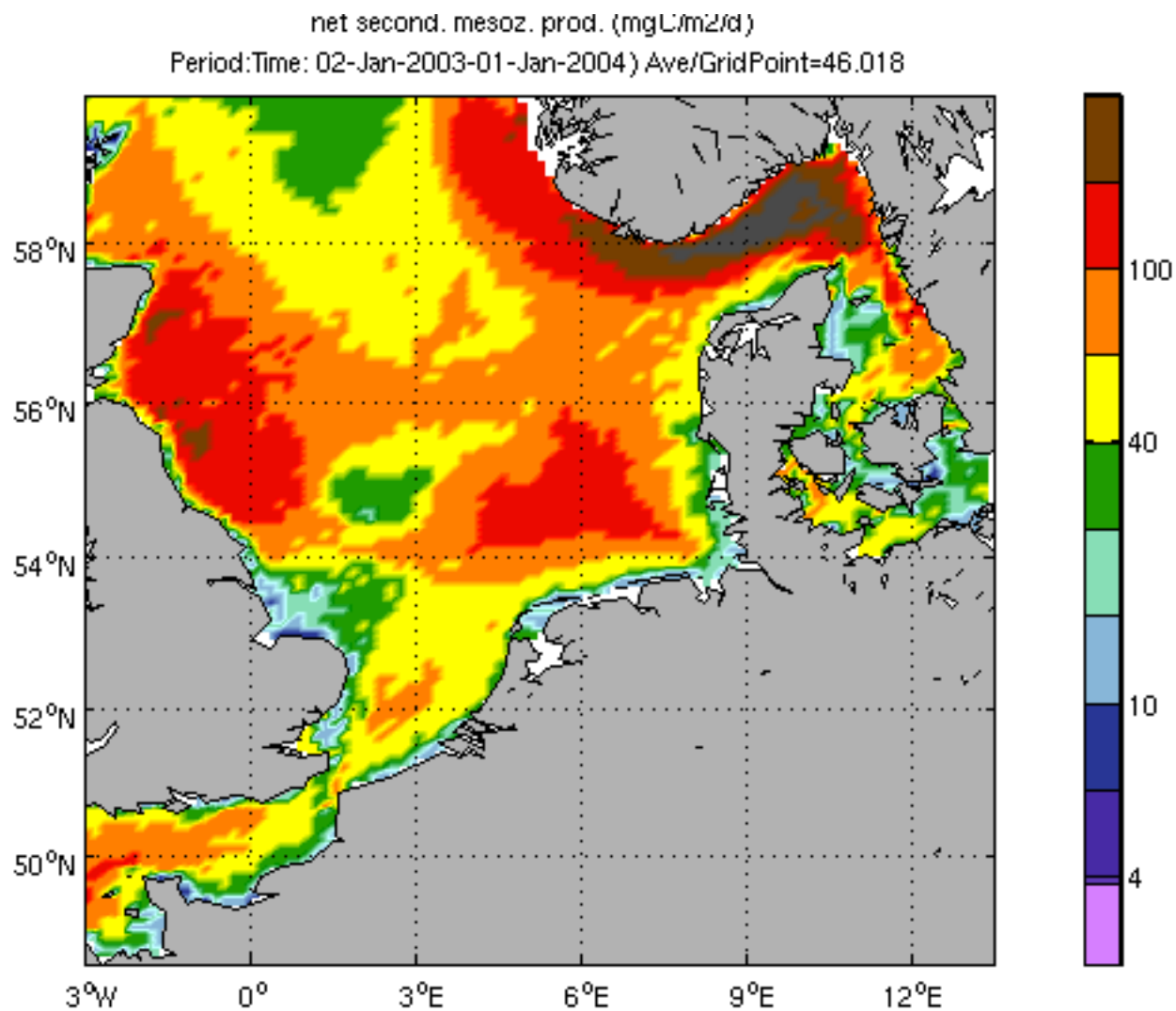



Nett Filter feeder Production : $15.1 \text{ gC m}^{-2} \text{ y}^{-1}$

net filterfeeder produc. (mgC/m²/d)
Period:Time: 02-Jan-2003-01-Jan-2004) Ave/GridPoint=41.5796

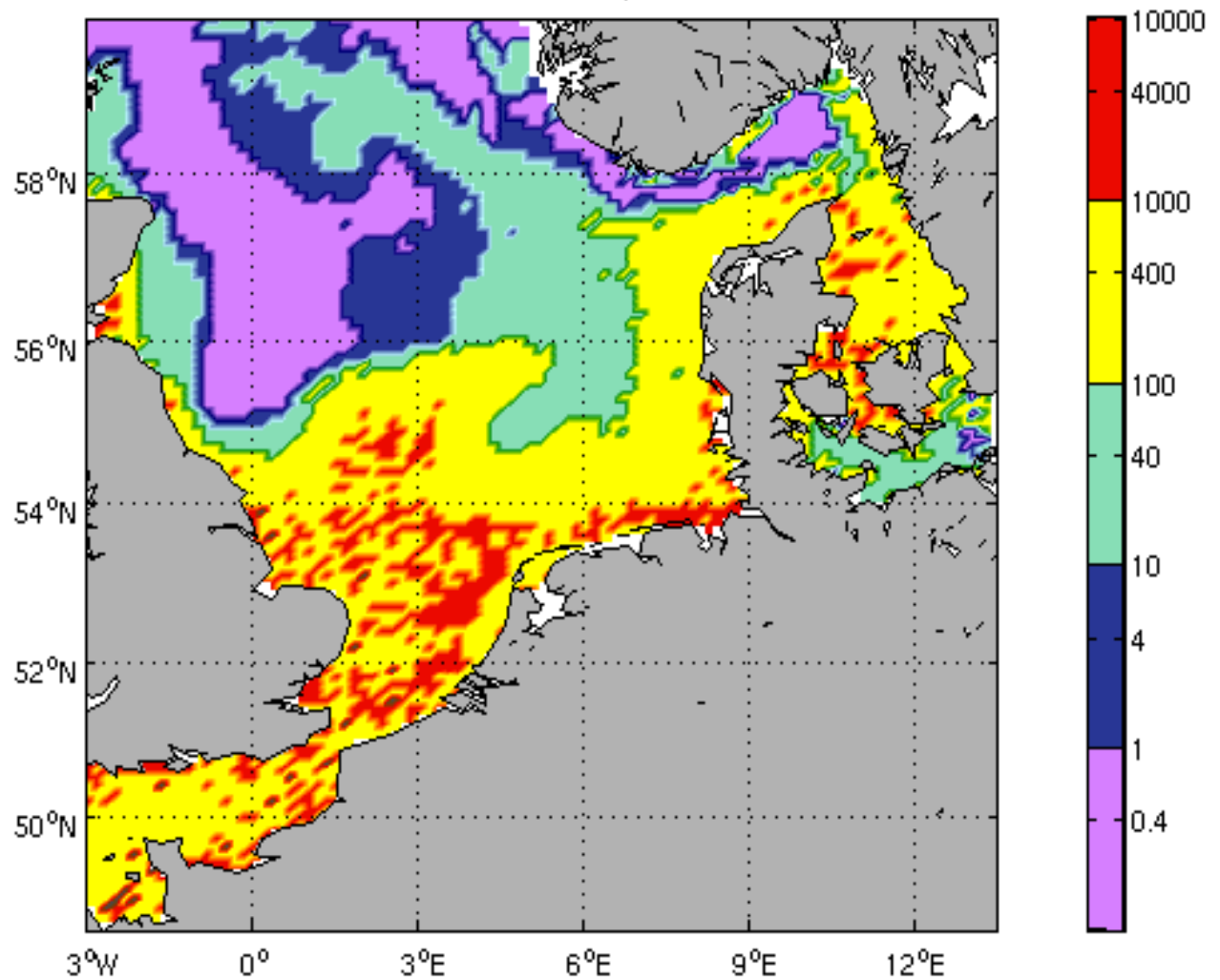



Calculation of food availability for fish ($\text{mgC m}^{-2} \text{y}^{-1}$)

- Use the closure of the pelagic and the benthic model!
- The losses of the highest trophic levels in the model
 - due to density dependent mortality
 - self grazing

can be seen as a measure for food availability for fish

- Highest trophic levels:
 - Pelagic: omnivorous + carnivorous zooplankton
 - Benthic: epibenthos + megabenthos



Food Availability for Pelagic fish : $13 \text{ gr C m}^{-2} \text{ y}^{-1}$

Potential Food Availability for Pelagic Fish (mgC/m²/d)
Period: Time: 02-Jan-2003-01-Jul-2003) Ave/GridPoint=35.6074

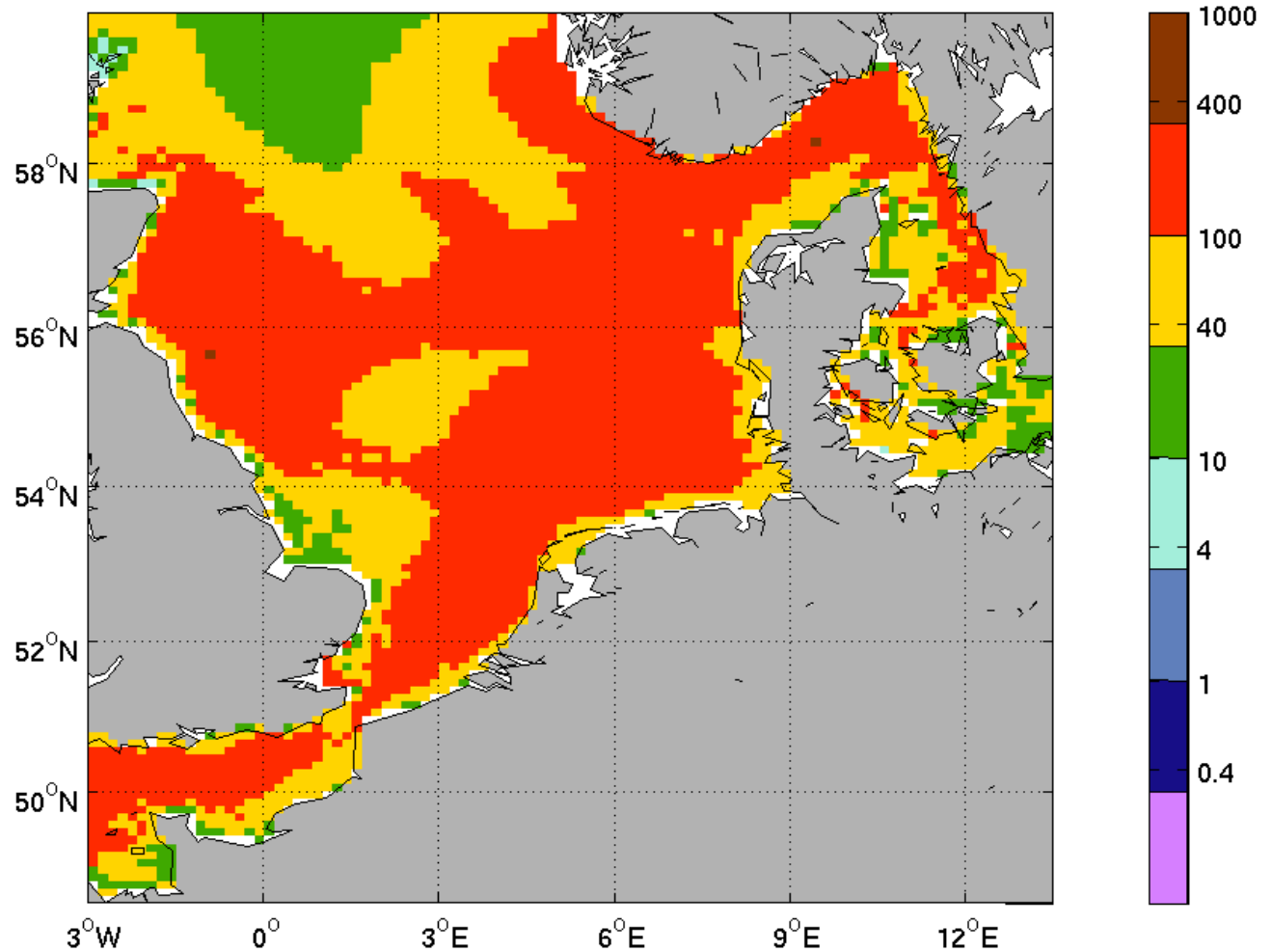



Food Availability for Benthic fish: $2 \text{ gr C m}^{-2} \text{ y}^{-1}$

Potential Food Availability for Benthic Fish ($\text{mgC}/\text{m}^2/\text{d}$)
Period: Time: 02-Jan-2003-01-Jul-2003) Ave/GridPoint=5.4972

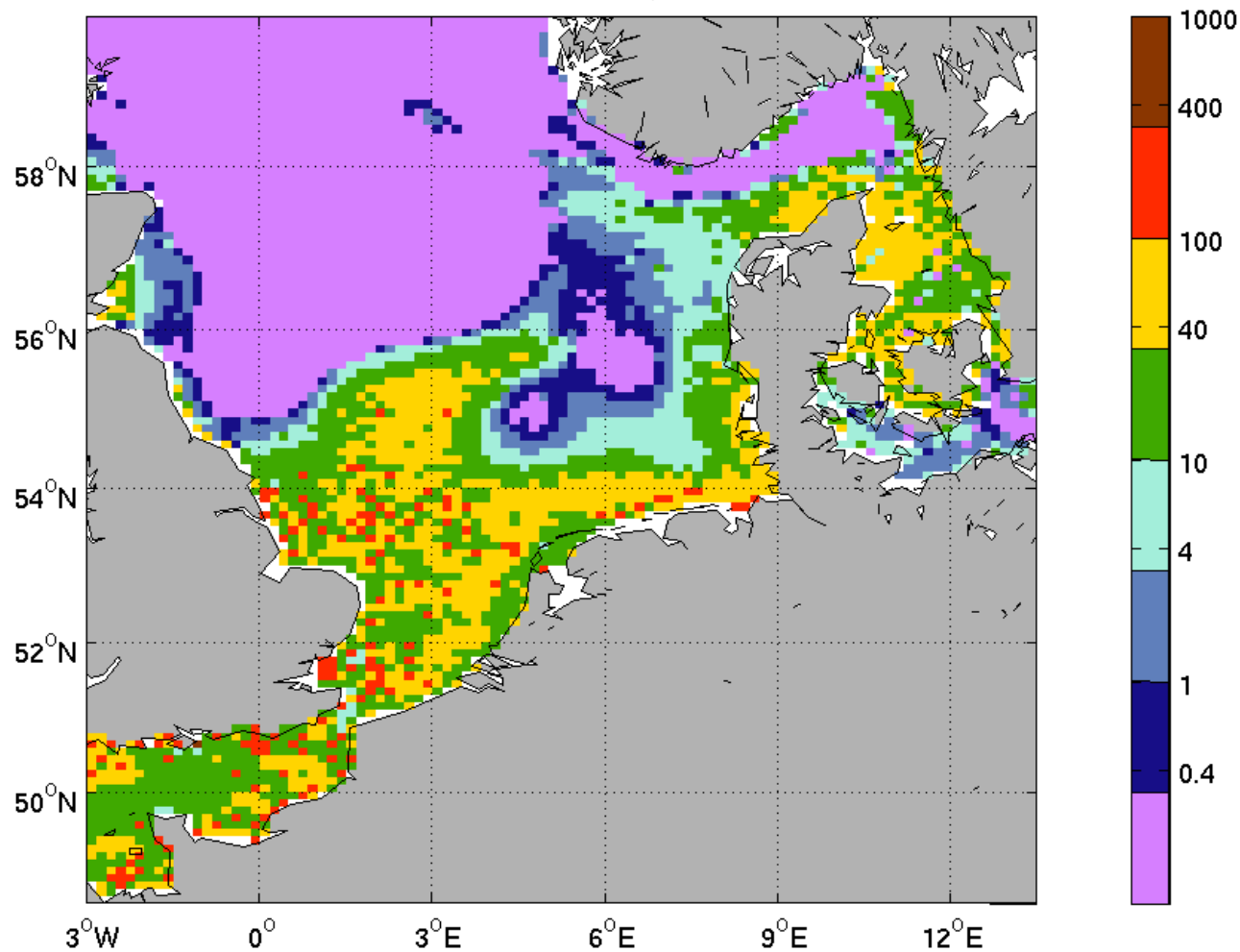



Summary:

- Summary:
 - We have a model with benthic-pelagic coupling!
 - With appropriate biomass levels.
 - However for the temporal seasonal dynamics validation is needed!

Limitations: too simple modelling of higher trophic levels

- No size classes in benthic system
- No fishes..



Summary

Near future: :

- Replace Filter Feeder-model with size classed DEB model.
- Hind-cast period 1970-2000 to validate the model and look in more detail the eutrophication problems.
- Further testing of BFM for other areas. (BFM is applied for the Adriatic Sea, for the Mediterranean Sea, applied in a world-model).

Perspective:

- The possibility to use relative cheap computer to run coupled models will the make the use of models as research tools more profitable. The modelling will become a more democratic tool...